

# Kollmorgen Servo Systems Catalog



Micron™ Gearheads



AKM™ Servomotors



Cartridge Direct Drive Rotary™ Motors



Housed Direct Drive Rotary Motors



Direct Drive Linear Motors



Linear Positioners



Multi-Axis Precision Tables



**KOLLMORGEN**®

*Because Motion Matters™*

# Kollmorgen. Every solution comes from a real understanding of OEM challenges.

**The ever-escalating demands of the marketplace mean increased pressure on OEMs at every turn.** Time constraints. Demands for better performance. Having to think about the next-generation machine even before the current one is built. While expectations are enormous, budgets are not. Kollmorgen's innovative motion solutions and broad range of quality products help engineers not only overcome these challenges but also build truly differentiated machines.

**Because motion matters, it's our focus.** Motion can distinctly differentiate a machine and deliver a marketplace advantage by improving its performance. This translates to overall increased efficiency on the factory floor. Perfectly deployed machine motion can make your customer's machine more reliable and efficient, enhance accuracy and improve operator safety. Motion also represents endless possibilities for innovation. We've always understood this potential, and thus, have kept motion at our core, relentlessly developing products that offer precision control of speed, accuracy and position in machines that rely on complex motion.

**Removing the Barriers of Design, Sourcing, and Time**

At Kollmorgen, we know that OEM engineers can achieve a lot more when obstacles aren't in the way. So, we knock them down in three important ways:

**Integrating Standard and Custom Products**

The optimal solution is often not clear-cut. Our application expertise allows us to modify standard products or develop totally custom solutions across our whole product portfolio so that designs can take flight.

**Providing Motion Solutions, Not Just Components**

As companies reduce their supplier base and have less engineering manpower, they need a total system supplier with a wide range of integrated solutions. Kollmorgen is in full response mode with complete solutions that combine programming software, engineering services and best-in-class motion components.

**Global Footprint**

With direct sales, engineering support, manufacturing facilities, and distributors across North America, Europe, Middle East, and Asia, we're close to OEMs worldwide. Our proximity helps speed delivery and lend support where and when they're needed.

**Financial and Operational Stability**

Kollmorgen is part of Danaher Corporation, our \$13B parent company. A key driver in the growth of all Danaher divisions is the Danaher Business System, which relies on the principle of "kaizen" – or continuous improvement. Using world-class tools, cross-disciplinary teams of exceptional people evaluate processes, and develop plans that result in superior performance.

# Table of Contents

◆ <b>AKD™ Servo Drive</b>	2
◆ <b>AKD™ Servo Systems</b>	16
<b>AKM™ Servomotor</b>	18
<b>Direct Drive Technology</b>	24
<b>Cartridge Direct Drive Rotary™ Motors</b>	26
<b>Housed Direct Drive Rotary Motor</b>	30
<b>Linear Positioning Systems</b>	32
<b>Precision Tables DS4 / DS6 Series</b>	34
<b>Electric Cylinders N2 / EC Series</b>	38
<b>Rodless Actuators R-Series</b>	44
<b>Micron™ TRUE Planetary™ Gearheads</b>	50
◆ <b>Stepper Products</b>	54
◆ <b>Optimized Solutions</b>	58
◆ <b>Cables by Motor Type</b>	62
◆ <b>Model Nomenclature</b>	63
◆ <b>MOTIONEERING® Application Engine</b>	77

# AKD™ Servo Drive

**Our AKD Series is a complete range of Ethernet-based Servo Drives that are fast, feature-rich, flexible and integrate quickly and easily into any application.\*** AKD ensures plug-and-play commissioning for instant, seamless access to everything in your machine. And, no matter what your application demands, AKD offers industry-leading servo performance, communication options, and power levels, all in a smaller footprint.

This robust, technologically advanced family of drives delivers optimized performance when paired with our best-in-class components, producing higher quality results at greater speeds and more uptime. With Kollmorgen servo components, we can help you increase your machine's overall effectiveness by 50%.

\* Patents pending.

## Key Features

- Highest resolution feedback (up to 27-bit)
- High bandwidth torque-and-velocity loops – fastest digital torque loop in the market: 0.67  $\mu$ s
- Multi-function Bode Plot makes it easy to evaluate and optimize motion and machine performance
- Industry-leading and patent pending auto-tuning algorithms
- Advanced servo techniques such as high-order observer and bi-quad filters that yield industry-leading machine performance
- High resolution reference input (digital --> analog)

## Benefits

- Higher machine speed/throughput

- Powerful dual processor enables fast settling times

- Reduced scrap, better quality

- Powerful dual processor to hold programs/recipes
- Six-channel “real-time” software oscilloscope for fast commissioning and diagnostics
- Auto-complete of programmable commands saves looking up parameter names
- One-click capture and sharing of program plots and parameter settings allows you to send machine performance data instantly
- Best Graphical User Interface (GUI) in the market – extremely powerful and easy to use
- Robust and dependable quality

- Quicker changeover, greater uptime

- Supports a variety of single- and multi-turn feedback devices – Smart Feedback Device (SFD), EnDat2.2, 01, BiSS, Analog Sine/Cos encoder, incremental encoder, HIPERFACE<sup>®</sup>, and resolver
- Tightly integrated Ethernet motion buses on board base drive – EtherCAT<sup>®</sup>, SynqNet<sup>®</sup>, Modbus/TCP, and CANopen<sup>®</sup>
- Runs rotary and linear motors
- Widest range of programming options in the industry
- Seamlessly compatible with a range of front-end controls
- Industry-leading power density

- Quicker time to market

# AKD Servo Drive

The AKD Servo Drive delivers cutting-edge technology and performance with one of the most compact footprints in the industry. These feature-rich drives provide a solution for nearly any application, from basic torque-and-velocity applications, to indexing, to multi-axis programmable motion with embedded Kollmorgen Automation Suite™. The versatile AKD sets the standard for power density and performance.



Micron™ Gearheads

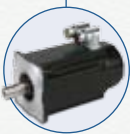

AKM™ Servomotors



Cartridge Direct Drive Rotary™ Motors



Housed Direct Drive Rotary Motors



Direct Drive Linear Motors\*



Linear Positioners



Multi-Axis Precision Tables

### Best-in-Class Components

AKD works seamlessly with Kollmorgen motors and positioners—well-known for quality, reliability, and performance.



\* For more information on our Direct Drive Linear Motors, visit [www.kollmorgen.com/brushlessddl](http://www.kollmorgen.com/brushlessddl)

# AKD Range of Coverage

When you pair the AKD Servo Drive with any of our Kollmorgen motors or linear positioners, you'll achieve optimized performance. From 3 to 24 Arms continuous current and 9 to 48 Arms peak current, the feature-rich AKD provides a solution for nearly any application.

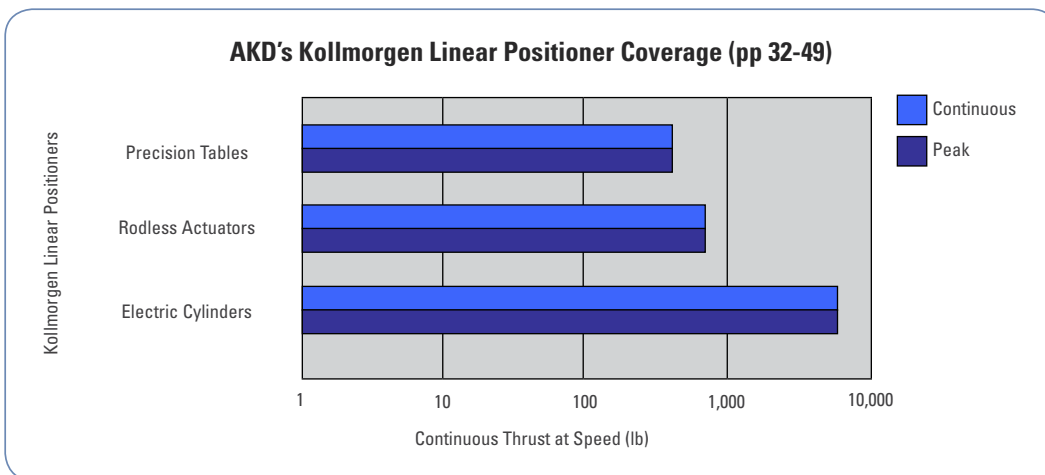
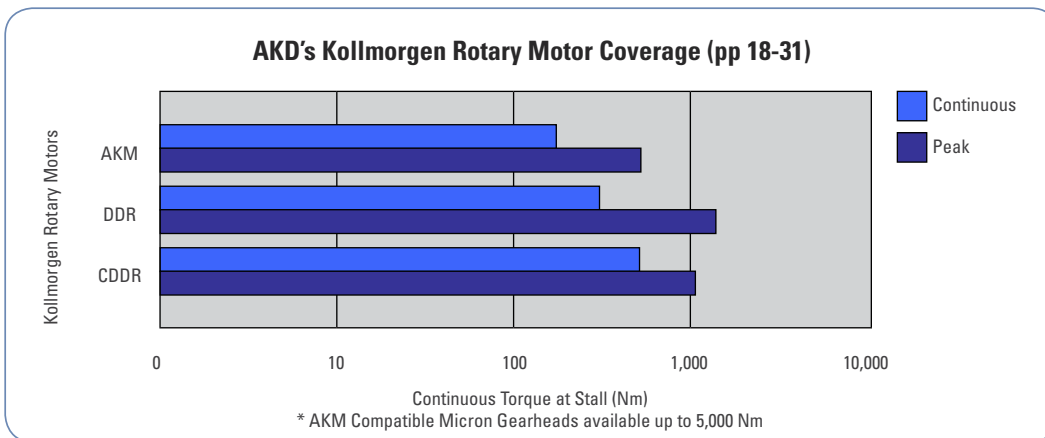
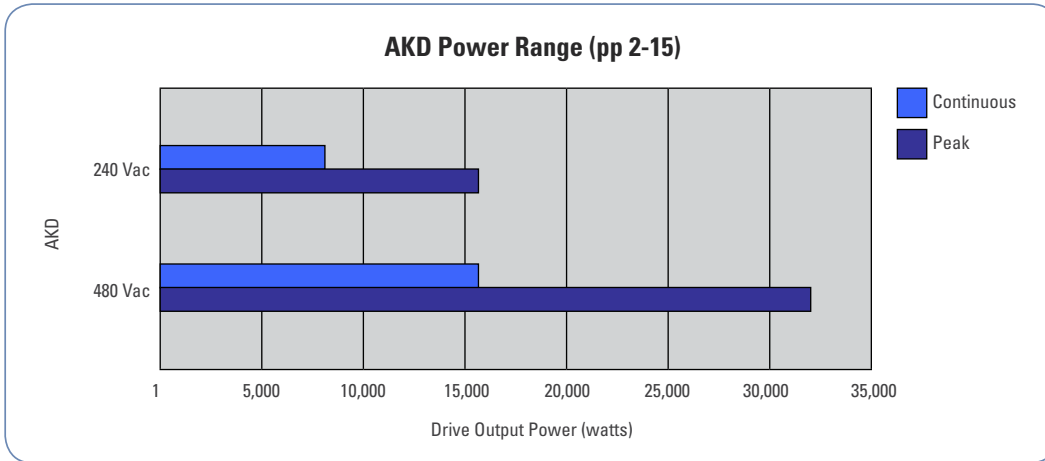



# AKD Servo Drive

AKD is specifically designed with the versatility, communications, and power you need to expand machine performance and increase integration speeds. Motor set-up is plug-and-play and multiple Ethernet connectivity options provide both open and closed protocols. Online trouble-shooting and data verification enable faster, bug-proof programming. And a broad power range in a smaller, compact design allows you to use these robust drives with a single interface.

Industry-leading high performance servo loops

## Performance Specifications

Servo Loop	Update Rate	Bandwidth (Max)
Current Loop	1.5 MHz, (0.67 $\mu$ s)	5.0 kHz
Velocity Loop	16 kHz, (62.5 $\mu$ s)	1.6 kHz
Position Loop	8 kHz, (125 $\mu$ s)	0.8 kHz

Inputs/Outputs		
Digital Input Events	16 Hz, (62.5 $\mu$ s) Update Rate	
Encoder Output or AUX Encoder Input	2.5 MHz Maximum Line Frequency	
Feedback	Smart Feedback Device (SFD), EnDat2.2, 01, BiSS, Analog Sine/Cos encoder, incremental encoder, HIPERFACE®, and resolver	
Logic Supply	24 Vdc	
	Base Drive	With I/O Expansion
Digital Input (24 Vdc)	8	20
Digital Output (24 Vdc)	3	13
Analog Input (+/- 10 Vdc, 16-bit)	1	2
Analog Input (+/- 10 Vdc, 16-bit)	1	2
Programmable Inputs	7	19
Programmable Outputs	2	12
Sink/Source Inputs/Outputs	Yes	Yes





Modbus/TCP



Industry-leading power density

## General Specifications

120 / 240 Vac 1 & 3Ø (85 -265 V)	Continuous Current (Arms)	Peak Current (Arms)	Drive Continuous Output Power (watts)	Power* (watts)	Internal Regen (watts) (ohms)		Height (mm)	Width (mm)	Depth (mm)	Depth with Cable Bend Radius (mm)
AKD-■00306	3	9	1100	500	0	0	168	57	153	184
AKD-■00606	6	18	2000	1000	0	0	168	57	153	184
AKD-■01206	12	30	4000	2000	100	15	195	76	186	215
AKD-■02406	24	48	8000	4000	200	8	250	100	230	265
AKD-■04806**	48	96	16,000	8000	200	5	<i>Coming in 2010</i>			
480 Vac 3Ø (187 -528 V)	Continuous Current (Arms)	Peak Current (Arms)	Drive Continuous Output Power (watts)	Power* (watts)	Internal Regen (watts) (ohms)		Height (mm)	Width (mm)	Depth (mm)	Depth with Cable Bend Radius (mm)
AKD-■00307	3	9	2000	1000	100	33	256	70	186	221
AKD-■00607	6	18	4000	2000	100	33	256	70	186	221
AKD-■01207	12	30	8000	4000	100	33	256	70	186	221
AKD-■02407	24	48	16,000	8000	200	23	310	105	229	264
AKD-■04807**	48	96	32,000	16,000	400	<i>Coming in 2010</i>				
AKD-■09607**	96	192	64,000	32,000	800	<i>Coming in 2010</i>				

Note: For complete AKD model nomenclature, refer to page 63.

\* Normal shaft power output at 40 degrees C ambient.

\*\* Available 2010.

# Scalable Programmability

The AKD Servo Drive delivers cutting-edge technology and performance with one of the most compact footprints in the industry. The AKD is flexible enough for virtually any application. From one axis that is as simple as analog torque and velocity, to 128 axes of fully programmable synchronized motion, AKD is the answer.

## Benefits

- Optimized performance in seconds
- Greater throughput and accuracy
- Easy-to-use Graphical User Interface (GUI) for faster commissioning and troubleshooting
- Flexible and scalable to meet any application



### Motion Tasking ("P" Option)

- Adds simple point-and-click indexing to base drive
- Provides user with pre-programmed options
- Guides novice user through simplified steps to create indexing moves
- Includes access to 11 digital I/O and 2 analog I/O on base drive
- Includes 2 high-speed digital inputs
- Expandable to 31 digital I/O and 4 analog I/O
- Same package size as base drive

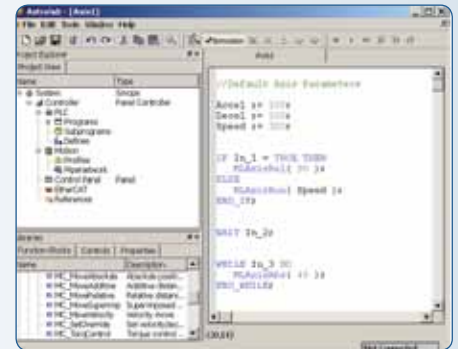

### Structured Text Programmable Single-Axis Drive ("T" Option)

- Adds simplified "basic-like" programmability to base AKD
- Greater functionality than simple indexing
- Code is easily portable to higher levels of programmability
- Includes access to 11 digital I/O and 2 analog I/O on base drive
- Includes 2 high-speed digital inputs
- Expandable to 31 digital I/O and 4 analog I/O
- Same package size as base drive

### Base AKD ("B" Option)

- Controlled by analog torque-and-velocity commands
- Includes electronic gearing via X9 connector
- Includes access to 11 digital I/O and 2 analog I/O on base drive
- Includes 2 high-speed digital inputs
- Expandable to 31 digital I/O and 4 analog I/O

Basic Operation

Single-Axis

# RANGE OF KOLLMORGEN AUTOMATION SUITE CAPABILITIES

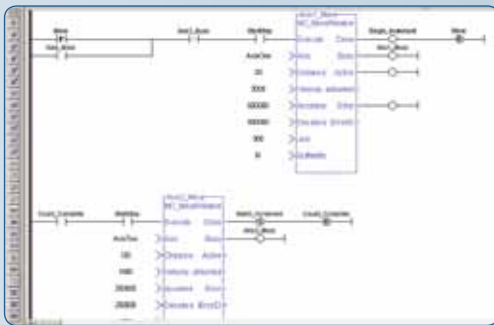

## Kollmorgen Automation Suite Programmable Drive

- Powerful 1.5 axis controller: new standard for performance!
- All five IEC 61131-3 languages (Structured Text, Function Block Diagram, Ladder Diagram, Instruction List, Sequential Function Chart) for process programming (soft PLC)
- PLCopen for motion programming
- Exclusive function blocks such as “wait” and “interrupt” so your program can act as a scanning language or sequential language
- Includes access to 11 digital I/O and 2 analog I/O on base drive
- Includes 2 high-speed digital inputs
- Expandable to 31 digital I/O and 4 analog I/O
- Same package size as base drive

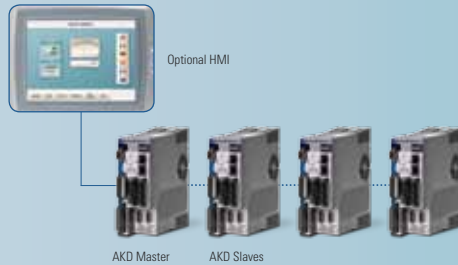

## Kollmorgen Automation Suite Programmable Multi-Axis Master

- True synchronized-path control of up to 4 axes
- Sets new standards for precision and optimizes nearly any application
- Easily manages remote I/O via EtherCAT in addition to all drives' I/O
- Pipe Network™ – program sophisticated camming and gearing applications in a matter of minutes
- Adds only 30 millimeters to width of drives below 12 Amps; same size as larger base drives
- Includes 11 digital I/O and 2 analog I/O per axis
- Includes 2 high-speed digital inputs per axis

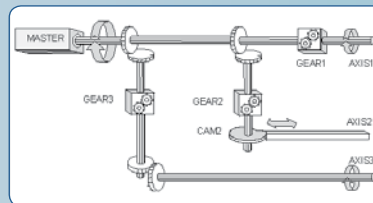

Using the exclusive Pipe Network™ provides a one-to-one translation of a mechanical system into a logical world.

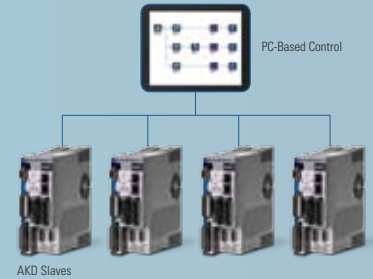

## Kollmorgen Automation Suite Programmable Automation Controller (PAC)

- Capable of controlling up to 128 axes using a PAC and EtherCAT-enabled base AKD
- Easily manages remote I/O via EtherCAT in addition to all drives' I/O
- Sets new standards for precision and optimizes nearly any application
- Pipe Network – program sophisticated camming and gearing applications in a matter of minutes
- Adds only 30 millimeters to width of drives below 12 Amps; same size as larger base drives
- Includes 11 digital I/O and 2 analog I/O per axis
- Includes 2 high-speed digital inputs per axis

IEC 61131-3 with five languages for process programming (soft PLC)

Choice of PLCopen or Kollmorgen *exclusive* Pipe Network for motion programming



Programming

Multi-Axis Programming

# Kollmorgen WorkBench

Our simple Graphical User Interface (GUI), Kollmorgen WorkBench, is designed to expedite and streamline the user's experience with AKD. From easy application selection and reduced math, to a sleek six-channel scope; the user interface is extremely easy to use. Kollmorgen WorkBench also makes auto-tuning the AKD high-performance drive with world-class Kollmorgen motors very simple.

## User-Friendly Environment

Logical flow, colorful icons and easy access simplify interactions with AKD. The folder structure allows for instant identification and easy navigation.

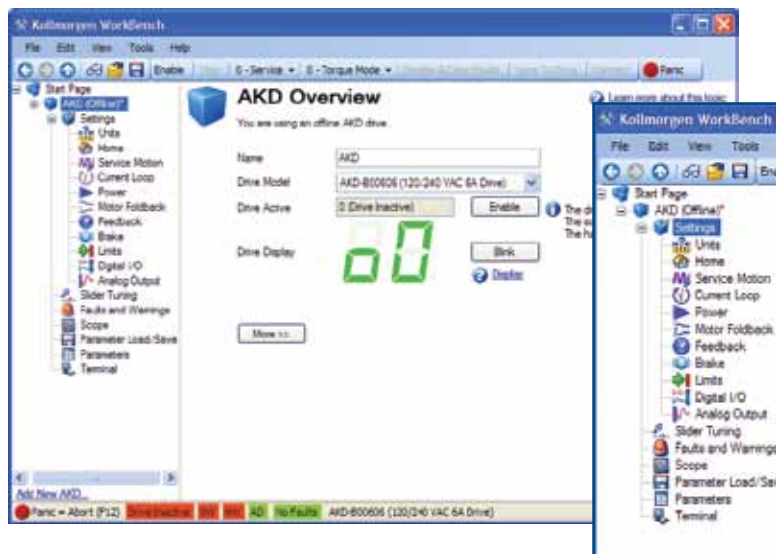

## Sleek Six-Channel "Real-Time" Software Oscilloscope

The easy-to-use AKD interface has a sleek digital oscilloscope that provides a comfortable environment for users to monitor performance. There are multiple options to share data in the format you prefer at the click of a button.

- Save as an image
- Load to an e-mail
- Print

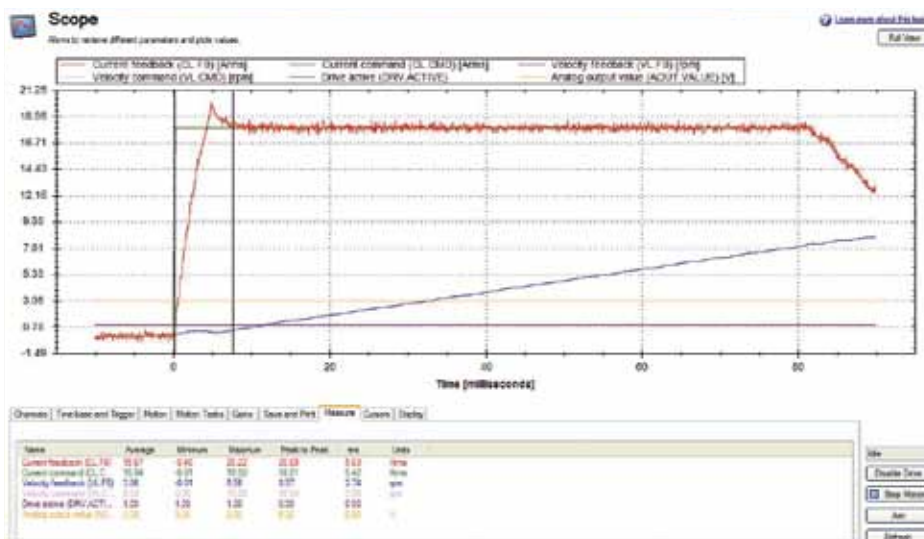

## Application Selection

Simplifies set-up by allowing use of machine or application-based units. Nip Roller and Rack and Pinion set-ups shown.

### Nip Roller Application Selection

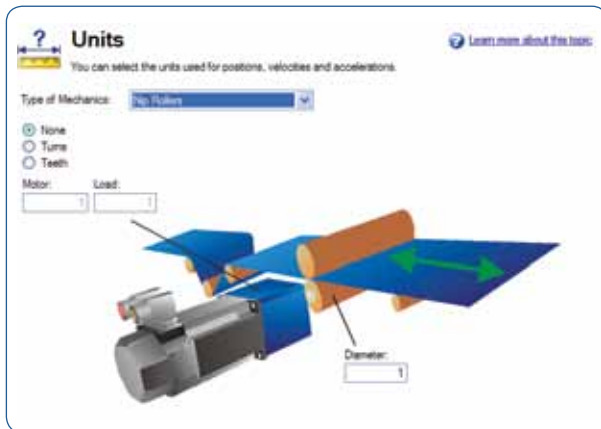

### Rack and Pinion Application Selection

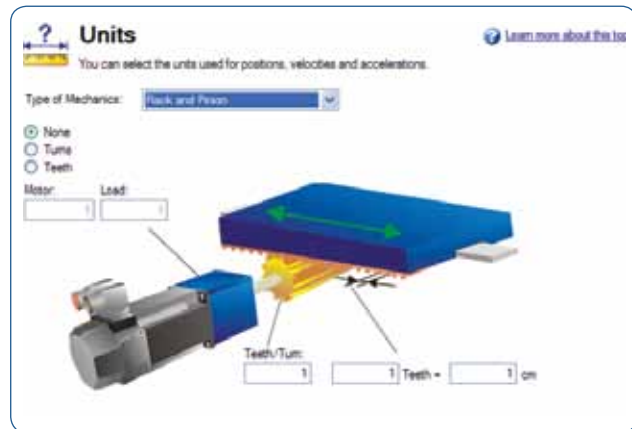

## Data-Sharing

The ease-of-sharing continues in the parameters window. Kollmorgen WorkBench provides the user the easy options of printing or emailing the parameter values at the click of a button.

Full Name	Value	Units	Parameter	Read/Write
<b>Active Disable</b>				
Deceleration during active disable	3000.000	rpm/s	AD DEC	read-write
Time-out	1000	ms	AD DISTO	read-write
State	0	ms	AD STATE	read-only
Velocity window	120.000	rpm	AD VELTHRESH	read-write
Time delay after velocity window	6	ms	AD VELTHRESHTM	read-write
<b>Analog Input</b>				
Analog input low pass filter cutoff freq.	5.000.000	Hz	AIN CUTOFF	read-write
Analog input signal deadband	0.000	V	AIN DEADBAND	read-write
Analog input mode	0 - Inactive		AIN MODE	read-write
Analog input offset	0.000	V	AIN OFFSET	read-write
Analog input signal	0.000	V	AIN VALUE	read-only
<b>Analog Input/Output</b>				
Analog input torque scale	0.001	A/V	AIO JSCALE	read-write
Analog input velocity scale	0.060	rpm/V	AIO VSCALE	read-write
<b>Analog Output</b>				
Analog output mode	0 - User Variable		AOUT.MODE	read-write
Analog output value	0.000	V	AOUT.VALUE	read-only
<b>Mode</b>				
<b>Current Loop</b>				
Current command	0.000	A	CLCMD	read-only
Current command - user	0.000	A	CLCMDU	read-write
Current command - D component	0.000	A	CLDCMD	read-only
Current command - user D component	0.000	A	CLDCMDU	read-write



# AKD Connector Layout and Functionality

## Ethernet Connectivity

- Ethernet-based AKD provides the user with multiple bus choices
- EtherCAT® (DSP402 protocol), Modbus/TCP, SynqNet®, and CANopen®
- EtherCAT and CANopen can be run simultaneously on the same AKD Drive
- No option cards are required



## Industrial Design

- Rugged circuit design and compact enclosure for space-saving, modern appearance – minimizes electrical noise emission and susceptibility
- Full fault protection
- UL, cUL listed, and CE
- No external line filters needed (480 Vac units) for CE & UL compliance
- Removable screw terminal connectors for easy connections
- DC Bus sharing



## Safe-Torque-Off (STO)

(IEC 61800 SIL2)

- Switches off the power stage to ensure personnel safety and prevents an unintended restart of the drive, even in fault condition
- Allows logic and communication to remain on during power stage shut down

## Plug-and-Play with Kollmorgen Motors and Positioners

- Electronic motor nameplates allow parameters to automatically load for fast commissioning
- Motion in seconds
- Custom motor parameters easily entered

## Internal Regenerative Braking Resistor

(All powers except 120/240 Vac 3 Arms and 6 Arms)

- Simplifies system components
- Saves overhead of managing external regeneration when internal regeneration is sufficient

## I/O (Base Drive)

- 8 digital inputs
- 2 high-speed digital inputs (maximum time delay of 1.0 μs)
- 3 digital outputs
- 1 analog input - 16 bit
- 1 analog output - 16 bit



## Auto-Tuning

- Optimized performance with auto-tuning, guided tuning, or manual tuning
- Handles inertia mismatches up to 1000:1
- Industry leading bandwidth under compliant and stiff load conditions, no matter the mechanical bandwidth of the machine



### AKD 120/240 Vac Connector Layout

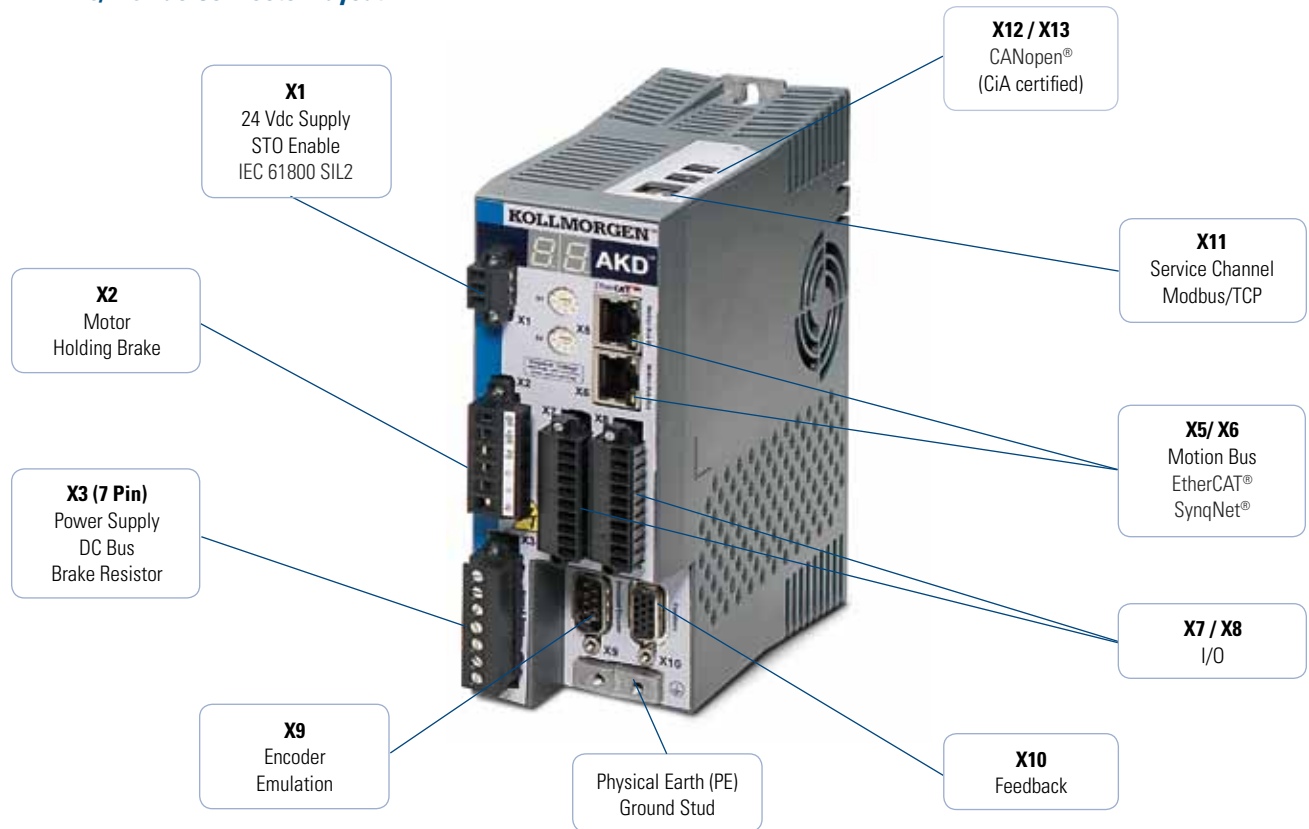

### AKD 480 Vac Connector Layout

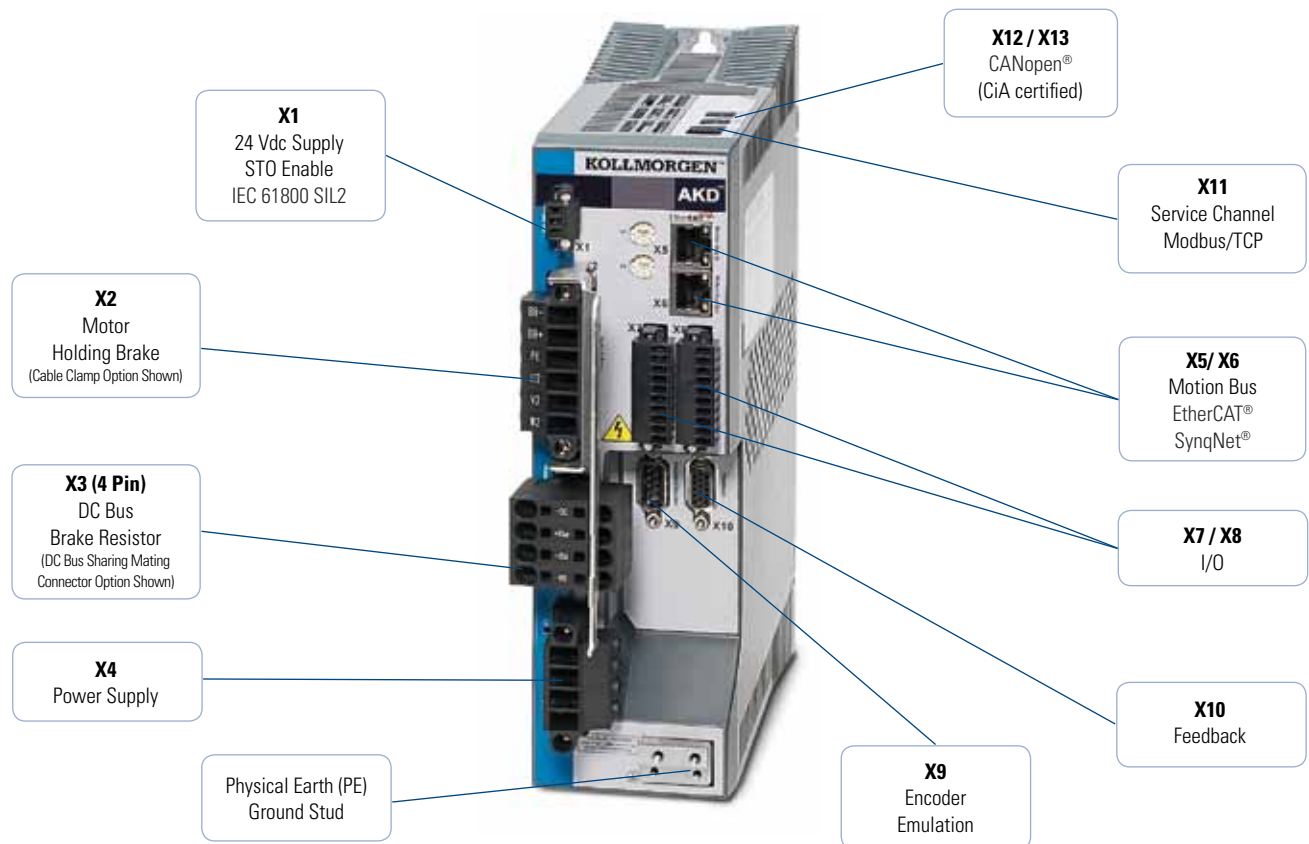



# Accessories

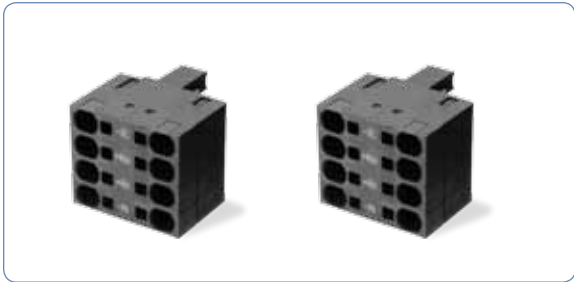

## Mating Connectors

The AKD series includes all screw type mating connectors. Alternative connectors for DC bus and mains sharing are available.



## Brake Resistors

We offer a full line of brake resistors up to 2500 watts. Brake resistors are impedance matched with AKD and are available in many sizes and form factors.



## Shielding Solutions

For noisy environments, we offer shielding kits that can be applied to our Flex Line Cables.



## Chokes and Filters

Line filters are offered to improve reliability and to protect the life of the machine in less stable environments. Motor chokes reduce radiated emissions and are recommended for applications with cable lengths >25 meters.

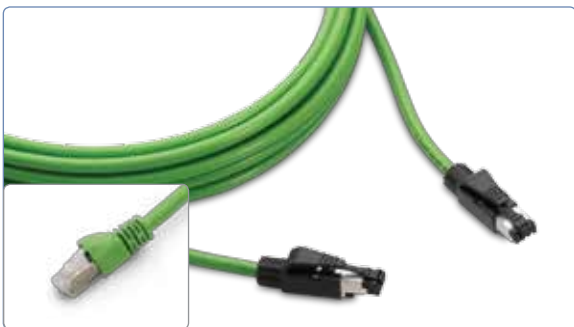

## Motion Bus and Service Port Cables

We offer industrial shielded PUR cables with RJ45 connections for demanding industrial environments. These cables outperform office cables in EMC resilience, durability, and life.



## I/O and Auxiliary Input Breakout Adapters

Our I/O breakout board is pre-populated with I/O switches and a power connection for quicker prototyping.

# Servo System Cables

Value Line motor and power cables are suitable for most standard applications. High performance Flex Line motor and power cables are available for trailing and flexing applications or where longer lengths are required.



## Mating Connectors

AKD drives include screw type mating connectors. Alternative connectors for DC bus and mains sharing are also available. D-sub and RJ-type connectors are not included.

## Specification Comparison

	Value Line	Flex Line
Lengths Offered	1, 3, 6, 9, 12 m	1-50 m, 1/2 m increments
Max Ampacity (continuous)	12 A	24 A
Static Flex Radius	10 x Cable Outside Dimension (OD)	10 x Cable Outside Dimension (OD)
Dynamic Flex (1,000,000 cycles)	Not Rated	15 x Cable Outside Dimension (OD)
Motor Connectors Available	Euro Style	Euro Style
Maximum Motor Connector IP rating	IP67	IP65
Cable Agency Approvals	RoHS, UL, CE	UL, CSA, CE, NEC, NFPA
Feedback Supported	SFD, EnDat2.2, 01, BiSS, Resolver, HIPERFACE®	SFD, Sine Encoder, EnDat2.2, 01, BiSS, Resolver, HIPERFACE®, Comcoder
Holding Brake	Available	Available

## Power Cables

AKD	Value Line	OD (mm)	Value Line with Brake	OD (mm)	Flex Line	OD (mm)	Flex Line with Brake	OD (mm)
3/6 Amp	VP-507BEAN-XX	9.4	VP-508CFAN-XX	10.9	CP-507CCAN-XX-X	12.7	CP-507CDAN-XX-X	14.5
12 Amp	VP-508CEAN-XX	10.3	VP-508CFAN-XX	10.9	CP-507CCAN-XX-X	12.7	CP-507CDAN-XX-X	14.5
20 Amp	VP-508DEAN-XX	11.7	VP-508DFAN-XX	12.9	CP-508DCAN-XX-X	14.5	CP-508DDAN-XX-X	16.6
24 Amp	Not Available	Not Available	Not Available	Not Available	CP-508EDBN-XX-X	18.3	CP-508EDBN-XX-X	18.3

## Feedback Cables

Feedback Type	Value Line	OD (mm)	Flex Line	OD (mm)
SFD	VF-DA0474N-XX	6.7	CF-DA0374N-XX-X	7.5
EnDat 2.1 / BiSS, HIPERFACE®	VF-SB4474N-XX	9.7	CF-SB7374N-XX-X	11.2
Resolver	VF-RA2474N-XX	9.7	CF-RA2574N-XX-X	9.5
Incremental / Comcoder	Not Available	Not Available	CF-CB7374N-XX-X	11.2

Note: Refer to page 62 for matching cables by motor type and drive.

# AKD Servo Systems

**When you need precise position control, choose from Kollmorgen's broad portfolio of AKD Servo System components.** Our unparalleled product line breadth provides great flexibility for any application. Whether it's any combination of motors and drives, cables, controller, electric cylinders or gearheads, all components are plug-and-play for easy, seamless integration. These best-in-class servo systems can be matched with single-axis or multi-axis motion controllers for a system solution that's precise, reliable and durable.

## Key Features

- Optimized AKM and Direct Drive motor windings to AKD Drive
- Plug-and-play motor-recognition drive commissioning for AKM, CDDR and DDR motor families
- Industry-leading and patent pending auto-tuning algorithms
- New lower cost multi-turn feedback option
- Industry-leading motor power density
- AKM offers 25 frame-stack combinations and nearly 120 standard windings in a single motor line
- CDDR offers 17 frame-stack combinations and 31 windings
- DDR offers 12 frame-stack combinations and 12 windings
- New IP67 protection class option for AKM

## Benefits

- Same size AKM delivers up to 47% more shaft power than before
- Reduction in drive size and motor size
- Reduction in system cost
- Reduction in set-up time for each servo system
- Immediate and adaptive response to dynamic loads optimizes performance in seconds
- Precise control of all motor types
- Compensation for stiff and compliant transmissions and couplings
- Improve machine precision with high resolution and improved accuracy
- Reduce cycle time and sensor-and-wiring costs by eliminating traditional homing methods
- Don't let motor size dictate the size of your machine
- Fit more motor into a smaller space than you thought possible
- Over 50,000 standard motor variations including a wide range of mounting, connectivity, feedback and other options
- Flexibility provides choices to help you find an exact-fit solution
- Simplifies or eliminates mechanical modifications and engineering adaptation
- Apply AKM into hostile industrial applications with confidence and long-term reliability

# AKM Servomotor

The AKM™ Brushless Servomotor stands alone in the marketplace in terms of flexibility and performance advantages. Kollmorgen's culture of continuous improvement has paid dividends again. The AKM Servomotor's innovative design has been polished and optimized. With the new AKD amplifier, the venerable AKM Servomotor sets a new standard of refined servo performance, designed to deliver precise motion and more power for your money. Nowhere else will you find a more versatile and complete servo family to meet your needs and exceed your expectations.



## Features

- 7 frame sizes (40 to 188 mm)
- 25 frame-stack length combinations
- Multiple windings for low-voltage, 120/240/400/480 Vac operation
- Flexible flange mount and shaft options
- Industry leading low-cogging contributing to extreme smoothness
- Wide feedback options for high-performance and precision or rugged environment
- Unmatched customization – special windings, special shafts, and much more

## AKD with AKM Plug-and-Play Feedback

These feedback devices include electronic motor nameplates allowing plug-and-play commissioning, eliminating the need for drive parameter set-up and servo loop tuning in most applications.

## Performance Data

AKM Motor		Single-turn Absolute			Multi-turn Absolute		
		Accuracy (arc-min)	Resolution (bits)	Motor Key	Accuracy (arc-min)	Resolution (bits)	Motor Key
Value Line	AKM1	16	24	C	–	–	–
	AKM2-3	9	24	C	8	20	LB
	AKM4-7	9	24	C	4.66	20	LB
Performance Line	AKM2-4	1.0	20	DA	1.0	20	DB
	AKM5-7	0.333	20	DA	0.333	20	DB

## AKM (Exploded) 3D Model Shows Key Design Features

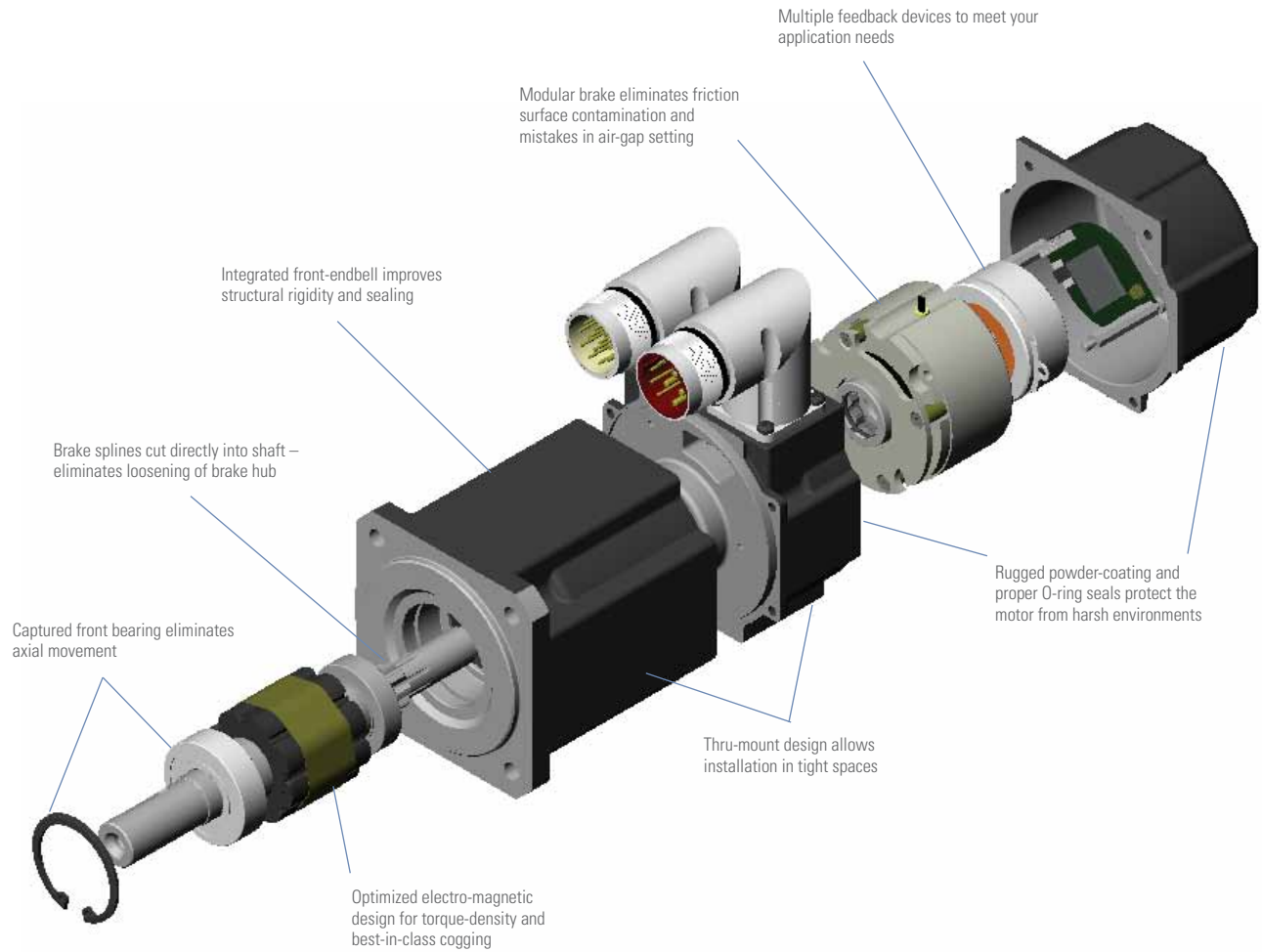

# AKM Servomotor

## Performance Data

AKM Motor	AKD Drive	Frame Size NEMA/ mm	Cont.Torque at stall Tcs Nm (lb-in)	Peak Torque at stall Tps Nm (lb-in)	Rated Speed Nrtd RPM	Power Prtd watts	Inertia (Jm) Kg-cm <sup>2</sup> (lb-in-s <sup>2</sup> x10 <sup>-3</sup> )	
120 Vac	AKM11B	AKD-X00306	17/ 40	0.18 (1.59)	0.61 (5.4)	4000	80	0.017 (0.0015)
	AKM11C	AKD-X00306	17/ 40	0.19 (1.68)	0.62 (5.5)	6000	110	0.017 (0.0015)
	AKM12C	AKD-X00306	17/ 40	0.31 (2.74)	1.08 (9.56)	4000	130	0.031 (0.00274)
	AKM12E	AKD-X00306	17/ 40	0.31 (2.74)	0.91 (8.05)	8000	230	0.031 (0.00274)
	AKM13C	AKD-X00306	17/ 40	0.41 (3.63)	1.46 (12.9)	3000	130	0.045 (0.0040)
	AKM13D	AKD-X00306	17/ 40	0.40 (3.54)	1.36 (12.0)	7000	270	0.045 (0.0040)
	AKM21C	AKD-X00306	23/ 60	0.48 (4.25)	1.48 (13.1)	2500	120	0.107 (0.0095)
	AKM21E	AKD-X00306	23/ 60	0.47 (4.16)	1.21 (10.7)	7000	300	0.107 (0.0095)
	AKM22C	AKD-X00306	23/ 60	0.84 (7.43)	2.39 (21.2)	1000	90	0.161 (0.0142)
	AKM22E	AKD-X00306	23/ 60	0.87 (7.70)	2.42 (21.4)	3500	290	0.107 (0.0095)
	AKM23D	AKD-X00306	23/ 60	1.15 (10.2)	3.89 (34.4)	1500	180	0.216 (0.0191)
	AKM23F	AKD-X00606	23/ 60	1.18 (10.4)	3.88 (34.3)	4500	500	0.216 (0.0191)
	AKM24D	AKD-X00306	23/ 60	1.40 (12.4)	4.84 (42.8)	1500	210	0.270 (0.0239)
	AKM24F	AKD-X00606	23/ 60	1.41 (12.5)	4.82 (42.7)	3000	420	0.270 (0.0239)
	AKM31E	AKD-X00306	na/ 80	1.20 (10.6)	3.23 (28.6)	2500	310	0.330 (0.0292)
	AKM32E	AKD-X00306	na/ 80	2.04 (18.1)	5.97 (52.8)	1000	210	0.590 (0.0522)
	AKM32H	AKD-X00606	na/ 80	2.10 (18.6)	6.22 (55.1)	3000	620	0.590 (0.0522)
	AKM33H	AKD-X00606	na/ 80	2.87 (25.4)	8.55 (75.7)	2500	690	0.850 (0.0752)
	AKM41E	AKD-X00306	34/ 90	2.01 (17.8)	5.33 (47.2)	1200	240	0.810 (0.0717)
	AKM41H	AKD-X00606	34/ 90	2.05 (18.1)	5.49 (48.6)	3000	580	0.810 (0.0717)
	AKM43H	AKD-X00606	34/ 90	4.82 (42.7)	14.0 (124)	1200	560	2.09 (0.185)
	AKM43L	AKD-X01206	34/ 90	4.73 (41.9)	11.7 (104)	3000	1190	2.09 (0.185)
	AKM44H	AKD-X00606	34/ 90	5.89 (43.3)	17.0 (150)	1000	570	2.73 (0.242)
	AKM51H	AKD-X00606	42/ 115	4.79 (42.4)	11.7 (104)	1200	560	3.42 (0.303)
AKM51L	AKD-X01206	42/ 115	4.89 (43.3)	10.6 (93.8)	3000	1240	3.42 (0.303)	
AKM52L	AKD-X01206	42/ 115	8.67 (76.7)	19.6 (173)	1500	1240	6.22 (0.551)	
AKM53L	AKD-X01206	42/ 115	11.6 (103)	26.5 (235)	1200	1350	9.12 (0.807)	
AKM54L	AKD-X01206	42/ 115	13.5 (119)	31.3 (277)	1200	1630	11.9 (1.06)	
240 Vac	AKM11B	AKD-X00306	17/ 40	0.18 (1.59)	0.61 (5.4)	8000	140	0.017 (0.0015)
	AKM12C	AKD-X00306	17/ 40	0.31 (2.74)	1.08 (9.56)	8000	230	0.031 (0.00274)
	AKM13C	AKD-X00306	17/ 40	0.41 (3.63)	1.46 (12.9)	8000	300	0.045 (0.0040)
	AKM21C	AKD-X00306	23/ 60	0.48 (4.25)	1.48 (13.1)	8000	320	0.107 (0.0095)
	AKM22C	AKD-X00306	23/ 60	0.84 (7.43)	2.73 (24.2)	3500	290	0.161 (0.0142)
	AKM22E	AKD-X00306	23/ 60	0.87 (7.70)	2.42 (21.4)	8000	580	0.161 (0.0142)
	AKM23D	AKD-X00306	23/ 60	1.15 (10.2)	3.89 (34.4)	5000	530	0.216 (0.0191)
	AKM23F	AKD-X00606	23/ 60	1.18 (10.4)	3.88 (34.3)	8000	780	0.216 (0.0191)
	AKM24D	AKD-X00306	23/ 60	1.40 (12.4)	4.84 (42.8)	4000	540	0.270 (0.0239)
	AKM24F	AKD-X00606	23/ 60	1.41 (12.5)	4.82 (42.7)	8000	930	0.270 (0.0239)
	AKM31C	AKD-X00306	na/ 80	1.15 (10.2)	3.87 (34.3)	2500	290	0.330 (0.0292)
	AKM31E	AKD-X00306	na/ 80	1.20 (10.6)	3.23 (28.6)	6000	600	0.330 (0.0292)
	AKM32E	AKD-X00306	na/ 80	2.04 (18.1)	5.97 (52.8)	3000	600	0.590 (0.0522)
	AKM32H	AKD-X00606	na/ 80	2.10 (18.6)	6.22 (55.1)	7000	1060	0.590 (0.0522)
	AKM33E	AKD-X00306	na/ 80	2.80 (24.8)	8.95 (79.2)	2000	550	0.850 (0.0752)
	AKM33H	AKD-X00606	na/ 80	2.87 (25.4)	8.55 (75.7)	5500	1300	0.850 (0.0752)
	AKM41E	AKD-X00306	34/ 90	2.01 (17.8)	5.33 (47.2)	3000	570	0.810 (0.0717)
	AKM41H	AKD-X00606	34/ 90	2.05 (18.1)	5.49 (48.6)	6000	1010	0.810 (0.0717)
	AKM42E	AKD-X00306	34/ 90	3.42 (30.3)	9.74 (86.2)	1800	590	1.45 (0.128)
	AKM42G	AKD-X00606	34/ 90	3.51 (31.1)	11.0 (97.4)	3500	1060	1.45 (0.128)
	AKM43H	AKD-X00606	34/ 90	4.82 (42.7)	14.0 (124)	3000	1210	2.09 (0.185)
	AKM43L	AKD-X01206	34/ 90	4.73 (41.9)	11.7 (104)	6000	1590	2.09 (0.185)
	AKM44E	AKD-X00306	34/ 90	5.79 (51.2)	16.5 (146)	1200	660	2.73 (0.242)
	AKM44H	AKD-X00606	34/ 90	5.89 (43.3)	17.0 (150)	2500	1220	2.73 (0.242)

Note 1: Refer to page 62 for matching cables.

Note 2: For complete AKD and AKM model nomenclature, refer to pages 63 and 64 respectively.



## Performance Data

	AKM Motor	AKD Drive	Frame Size NEMA/ mm	Cont.Torque at stall Tcs Nm (lb-in)	Peak Torque at stall Tps Nm (lb-in)	Rated Speed Nrt'd RPM	Power Prtd watts	Inertia (Jm) Kg-cm <sup>2</sup> (lb-in-s <sup>2</sup> x10 <sup>-3</sup> )
240 Vac	AKM51H	AKD-X00606	42/ 115	4.79 (42.4)	11.7 (104)	3000	1220	3.42 (0.303)
	AKM51L	AKD-X01206	42/ 115	4.89 (43.3)	10.6 (93.8)	6000	1260	3.42 (0.303)
	AKM52H	AKD-X00606	42/ 115	8.48 (75.1)	21.6 (191)	1800	1420	6.22 (0.551)
	AKM52L	AKD-X01206	42/ 115	8.67 (76.7)	19.6 (173)	3500	2350	6.22 (0.551)
	AKM53H	AKD-X00606	42/ 115	10.5 (92.9)	27.8 (246)	1500	1650	9.12 (0.807)
	AKM53L	AKD-X01206	42/ 115	11.6 (103)	26.5 (235)	2500	2510	9.12 (0.807)
	AKM54H	AKD-X00606	42/ 115	14.2 (126)	37.5 (332)	1000	1400	11.9 (1.06)
	AKM54L	AKD-X01206	42/ 115	13.5 (119)	31.3 (277)	2500	3010	11.9 (1.06)
	AKM62H	AKD-X00606	na/ 142	11.9 (105)	29.61 (262)	1000	1170	16.9 (1.50)
	AKM62L	AKD-X01206	na/ 142	12.2 (108)	26.3 (233)	2500	2620	16.9 (1.50)
	AKM63L	AKD-X01206	na/ 142	16.8 (149)	39.3 (348)	1500	2330	24.2 (2.14)
	AKM63N	AKD-X02406	na/ 142	17.0 (150)	40.3 (357)	3000	4080	24.2 (2.14)
	AKM64L	AKD-X01206	na/ 142	19.7 (174)	44.4 (393)	1500	2890	31.6 (2.80)
	AKM64Q	AKD-X02406	na/ 142	19.5 (173)	43.1 (381)	3000	4810	31.6 (2.80)
	AKM65L	AKD-X01206	na/ 142	24.6 (218)	55.4 (490)	1300	3040	40.0 (3.54)
	AKM65P	AKD-X02406	na/ 142	24.5 (217)	53.9 (477)	2400	4790	40.0 (3.54)
	AKM72P	AKD-X02406	na/ 180	29.5 (261)	65.8 (606)	1800	4500	64.5 (5.71)
	AKM72Q	AKD-X02406	na/ 180	24.5 (217)	56.0 (496)	2000	4860	64.5 (5.71)
	AKM73P	AKD-X02406	na/ 180	41.4 (366)	95.3 (828)	1300	4700	92.1 (8.15)
	AKM73Q	AKD-X02406	na/ 180	33.0 (292)	76.1 (674)	1500	5250	92.1 (8.15)
AKM74Q	AKD-X02406	na/ 180	46.8 (414)	90.7 (803)	1200	5380	120 (10.6)	
400 Vac	AKM22C	AKD-X00307	23/ 60	0.84 (7.43)	2.73 (24.2)	8000	570	0.161 (0.0142)
	AKM23D	AKD-X00307	23/ 60	1.15 (10.2)	3.89 (34.4)	8000	760	0.216 (0.0191)
	AKM24D	AKD-X00307	23/ 60	1.40 (12.4)	4.84 (42.8)	8000	920	0.270 (0.0239)
	AKM31C	AKD-X00307	na/ 80	1.15 (10.2)	3.87 (34.3)	5000	520	0.330 (0.0292)
	AKM32E	AKD-X00307	na/ 80	2.04 (18.1)	5.97 (52.8)	6500	1020	0.590 (0.0522)
	AKM33E	AKD-X00307	na/ 80	2.80 (24.8)	8.95 (79.2)	4500	1100	0.850 (0.0752)
	AKM41E	AKD-X00307	34/ 90	2.01 (17.8)	5.33 (47.2)	6000	990	0.810 (0.0717)
	AKM42E	AKD-X00307	34/ 90	3.42 (30.3)	9.74 (86.2)	3500	1030	1.45 (0.128)
	AKM42G	AKD-X00607	34/ 90	3.51 (31.1)	11.0 (97.4)	6000	1470	1.45 (0.128)
	AKM43H	AKD-X00607	34/ 90	4.82 (42.7)	14 (124)	5500	1620	2.09 (0.185)
	AKM44E	AKD-X00307	34/ 90	5.79 (51.2)	16.5 (146)	2000	1010	2.73 (0.242)
	AKM44H	AKD-X00607	34/ 90	5.89 (43.3)	17.0 (150)	4500	1640	2.73 (0.242)
	AKM51H	AKD-X00607	42/ 115	4.79 (42.4)	11.7 (104)	6000	1230	3.42 (0.303)
	AKM52H	AKD-X00607	42/ 115	8.48 (75.1)	21.6 (191)	3500	2290	6.22 (0.551)
	AKM52L	AKD-X01207	42/ 115	8.67 (76.7)	19.6 (173)	6000	2050	6.22 (0.551)
	AKM53H	AKD-X00607	42/ 115	10.5 (92.9)	27.8 (246)	3000	2770	9.12 (0.807)
	AKM53L	AKD-X01207	42/ 115	11.6 (103)	26.5 (235)	5000	3140	9.12 (0.807)
	AKM54H	AKD-X00607	42/ 115	14.2 (126)	37.5 (332)	1800	2350	11.9 (1.06)
	AKM54L	AKD-X01207	42/ 115	13.5 (119)	31.3 (277)	4500	3830	11.9 (1.06)
	AKM62H	AKD-X00607	na/ 142	11.9 (105)	29.6 (262)	2000	2140	16.9 (1.50)
	AKM62L	AKD-X01207	na/ 142	12.2 (108)	26.3 (233)	5000	3880	16.9 (1.50)
	AKM63L	AKD-X01207	na/ 142	16.8 (149)	39.3 (348)	3000	4040	24.2 (2.14)
	AKM63N	AKD-X02407	na/ 142	17.0 (150)	40.3 (357)	5000	4900	24.2 (2.14)
	AKM64L	AKD-X01207	na/ 142	19.7 (174)	44.4 (393)	3000	4900	31.6 (2.80)
	AKM64Q	AKD-X02407	na/ 142	19.5 (173)	43.1 (381)	5000	5600	31.6 (2.80)
	AKM65L	AKD-X01207	na/ 142	24.6 (218)	55.4 (490)	2500	5030	40.0 (3.54)
	AKM65P	AKD-X02407	na/ 142	24.5 (217)	53.9 (477)	4000	6240	40.0 (3.54)
	AKM72L	AKD-X01207	na/ 180	30.0 (266)	70.5 (624)	1500	3970	64.5 (5.71)
	AKM72P	AKD-X02407	na/ 180	29.5 (261)	68.5 (606)	3000	6280	64.5 (5.71)
	AKM72Q	AKD-X02407	na/ 180	24.5 (217)	56.0 (496)	4000	6830	64.5 (5.71)
	AKM73L	AKD-X01207	na/ 180	41.7 (369)	95.4 (844)	1400	5060	92.1 (8.15)
	AKM73P	AKD-X02407	na/ 180	41.4 (366)	93.5 (828)	2400	7130	92.1 (8.15)
AKM73Q	AKD-X02407	na/ 180	33.0 (292)	76.1 (674)	3000	7920	92.1 (8.15)	
AKM74L	AKD-X01207	na/ 180	49.7 (440)	114 (1010)	1200	5470	120 (10.6)	
AKM74P	AKD-X02407	na/ 180	52.3 (463)	125 (1110)	1800	7050	120 (10.6)	
AKM74Q	AKD-X02407	na/ 180	46.8 (414)	90.7 (803)	2500	8250	120 (10.6)	

Note 1: Refer to page 62 for matching cables.

Note 2: For complete AKD and AKM model nomenclature, refer to pages 63 and 64 respectively.

# AKM Servomotor

## Performance Data

AKM Motor	AKD Drive	Frame Size NEMA/ mm	Cont.Torque at stall Tes Nm (lb-in)	Peak Torque at stall Tps Nm (lb-in)	Rated Speed Nrt'd RPM	Power Prtd watts	Inertia (Jm) Kg-cm <sup>2</sup> (lb-in-s <sup>2</sup> x10 <sup>-3</sup> )
AKM22C	AKD-X00307	23/ 60	0.84 (7.43)	2.34 (20.7)	8000	570	0.161 (0.0142)
AKM23D	AKD-X00307	23/ 60	1.15 (10.2)	3.89 (34.4)	8000	760	0.216 (0.0191)
AKM24D	AKD-X00307	23/ 60	1.40 (12.4)	4.84 (42.8)	8000	920	0.270 (0.0239)
AKM31C	AKD-X00307	na/ 80	1.15 (10.2)	3.35 (29.7)	6000	570	0.330 (0.0292)
AKM32E	AKD-X00307	na/ 80	2.04 (18.1)	5.97 (52.8)	8000	1020	0.590 (0.0522)
AKM33E	AKD-X00307	na/ 80	2.80 (24.8)	8.95 (79.2)	5000	1190	0.850 (0.0752)
AKM41E	AKD-X00307	34/ 90	2.01 (17.8)	5.33 (47.2)	6000	990	0.810 (0.0717)
AKM42E	AKD-X00307	34/ 90	3.42 (30.3)	9.74 (86.2)	4000	1140	1.45 (0.128)
AKM42G	AKD-X00607	34/ 90	3.51 (31.1)	11.0 (97.4)	6000	1470	1.45 (0.128)
AKM43H	AKD-X00607	34/ 90	4.82 (42.7)	14.0 (124)	6000	1620	2.09 (0.185)
AKM44E	AKD-X00307	34/ 90	5.79 (51.2)	16.5 (146)	2500	1200	2.73 (0.242)
AKM44H	AKD-X00607	34/ 90	5.89 (43.3)	17.0 (150)	5500	1690	2.73 (0.242)
AKM51H	AKD-X00607	42/ 115	4.79 (42.4)	11.7 (104)	6000	1230	3.42 (0.303)
AKM52H	AKD-X00607	42/ 115	8.48 (75.1)	21.6 (191)	4000	2420	6.22 (0.551)
AKM52L	AKD-X01207	42/ 115	8.67 (76.7)	19.6 (173)	6000	2050	6.22 (0.551)
AKM53H	AKD-X00607	42/ 115	10.5 (92.9)	27.8 (246)	3000	2770	9.12 (0.807)
AKM53L	AKD-X01207	42/ 115	11.6 (103)	26.5 (235)	6000	2540	9.12 (0.807)
AKM54H	AKD-X00607	42/ 115	14.2 (126)	37.5 (332)	2000	2560	11.9 (1.06)
AKM54L	AKD-X01207	42/ 115	13.5 (119)	31.3 (277)	5000	3690	11.9 (1.06)
AKM62H	AKD-X00607	na/ 142	11.9 (105)	29.6 (262)	2400	2480	16.9 (1.50)
AKM62L	AKD-X01207	na/ 142	12.2 (108)	26.3 (233)	6000	3610	16.9 (1.50)
AKM63L	AKD-X01207	na/ 142	16.8 (149)	39.3 (348)	3500	4400	24.2 (2.14)
AKM63N	AKD-X02407	na/ 142	17.0 (150)	40.3 (357)	6000	4400	24.2 (2.14)
AKM64L	AKD-X01207	na/ 142	19.7 (174)	44.4 (393)	3500	5280	31.6 (2.80)
AKM64Q	AKD-X02407	na/ 142	19.5 (173)	43.1 (381)	6000	4620	31.6 (2.80)
AKM65L	AKD-X01207	na/ 142	24.6 (218)	55.4 (490)	2800	5450	40.0 (3.54)
AKM65P	AKD-X02407	na/ 142	24.5 (217)	53.9 (477)	4500	6360	40.0 (3.54)
AKM72L	AKD-X01207	na/ 180	30.0 (266)	70.5 (624)	1800	4580	64.5 (5.71)
AKM72P	AKD-X02407	na/ 180	29.5 (261)	68.5 (606)	3000	6680	64.5 (5.71)
AKM72Q	AKD-X02407	na/ 180	24.5 (217)	56.0 (496)	4500	6640	64.5 (5.71)
AKM73L	AKD-X01207	na/ 180	41.7 (369)	95.4 (844)	1500	5620	92.1 (8.15)
AKM73P	AKD-X02407	na/ 180	41.4 (366)	93.5 (828)	2400	7130	92.1 (8.15)
AKM73Q	AKD-X02407	na/ 180	33.0 (292)	76.1 (674)	3500	8060	92.1 (8.15)
AKM74L	AKD-X01207	na/ 180	49.7 (440)	114 (1010)	1400	6080	120 (10.6)
AKM74P	AKD-X02407	na/ 180	52.3 (463)	125 (1110)	1800	7050	120 (10.6)
AKM74Q	AKD-X02407	na/ 180	46.8 (414)	90.7 (803)	3000	8580	120 (10.6)

Note 1: Refer to page 62 for matching cables.

Note 2: For complete AKD and AKM model nomenclature, refer to pages 63 and 64 respectively.

### Model AKM23

Outline indicative of AKM1 – AKM4

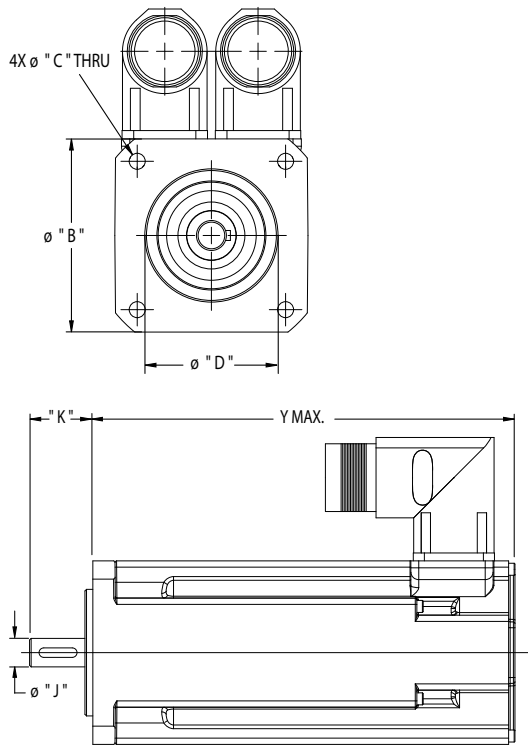

### Model AKM63

Outline indicative of AKM5 – AKM7

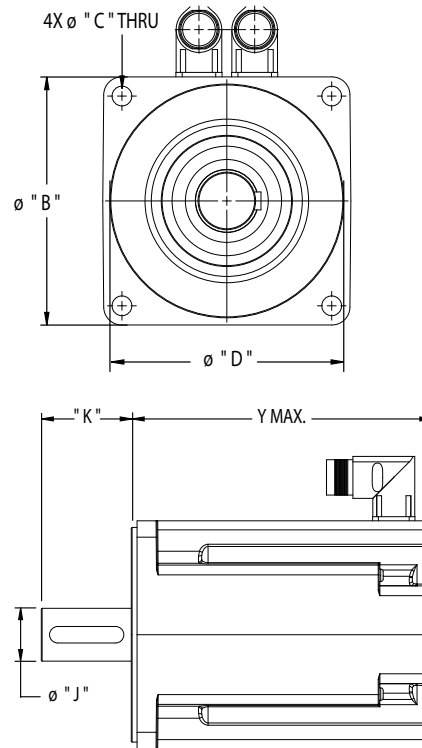

### Dimensions (mm)

Model	Shaft **	Shaft Length	Mount Hole **	Length 1 stack (AKMx1)	Length 2 stack (AKMx2)	Length 3 stack (AKMx3)	Length 4 stack (AKMx4)	Length 5 stack (AKMx5)	Brake Adder	Sine Enc. Adder *
	"J"	"K"	"C"	"Y"	"Y"	"Y"	"Y"	"Y"		
AKM1	8	25	4.3	79	98	117	n/a	n/a	n/a	n/a
AKM2	9	20	4.8	95.4	114.4	133.4	152.4	n/a	34.1	0
AKM3	14	30	5.8	109.8	140.8	178.8	205.8	n/a	30.5	0
AKM4	19	40	7	118.8	147.8	176.8	205.8	n/a	33.5	0
AKM5	24	50	9	127.5	158.5	189.5	220.5	n/a	45	18.5
AKM6	32	58	11	n/a	153.7	178.7	203.7	228.7	47	18.5
AKM7	38	80	13.5	n/a	192.5	226.5	260.5	n/a	42	9.5

Model	Frame Square "B"	Mount Pilot **	Mount B.C. **
AKM1	40	30	36
AKM2	58	40	63
AKM3	70	60	75
AKM4	84	80	100

Model	Frame Square "B"	Mount Pilot **	Mount B.C. **
AKM5	108	110	130
AKM6	138	130	165
AKM7	188	180	215

\* AKM5x w/ Sine Enc. and brake, plus adders, -2.0 mm.  
 AKM6x w/ Sine Enc. and brake, plus adders, +0.5 mm.  
 AKM7x w/ Sine Enc. and brake, plus adders, +9.3 mm.

\*\* Assumes the "A" international mount, other mounts available see AKM selection guide online.

# Direct Drive Technology (DDT)

Conventional servo systems commonly have a mechanical transmission which can consist of gears, gearheads, belts/pulleys or cams connected between the motor and the load.

With Direct Drive Technology, the mechanical transmission is eliminated and the motor is coupled directly to the load.

## Why Use Direct Drive Technology?

### Increased Accuracy and Repeatability

A “precision” planetary gearhead could have a backlash of 1 arc-minute. This can result in the load moving by 1 arc-minute with an absolutely stationary drive motor. Kollmorgen’s standard direct drive rotary (DDR) servomotors have repeatability better than 1 arc-second. Therefore, a direct drive motor can hold a position 60 times better than a conventional motor/gearhead.

The increased accuracy of direct drive technology results in a higher quality product out of the machine:

- Print registration is more accurate
- Cut or feed lengths can be held more precisely
- Coordination with other machine axes is more accurate
- Indexing location is more exact
- Tuning issues due to backlash are eliminated

### Higher Bandwidth

Mechanical transmission components impose a limit on how fast a machine can start and stop and also extend the required settling time. These factors limit the possible throughput of a machine.

Direct drive technology removes these limitations and allows for much faster start/stop cycles and also provides greatly reduced settling time. This will allow a greater throughput from the machine. Users of direct drive systems have reported up to a 2X increase in throughput.

### Improved Reliability and Zero Maintenance

Gears, belts, and other mechanical transmission parts break. By eliminating these parts and using DDR motors, the reliability of the machine is improved. Gearheads require periodic lubrication and/or replacement in aggressive start/stop applications. Belts require periodic tightening. There are no time-wear components in a direct drive motor and consequently they require zero maintenance.

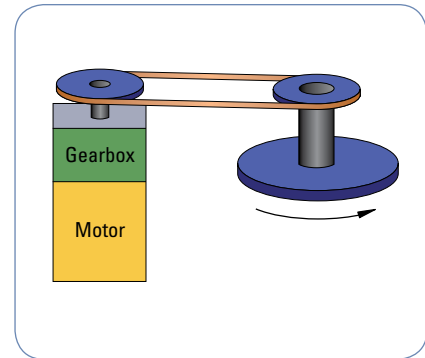

Servomotor and Gearhead

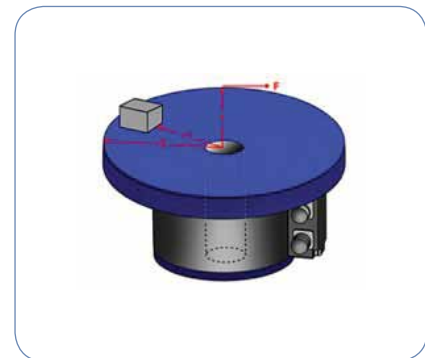

Direct Drive Motor

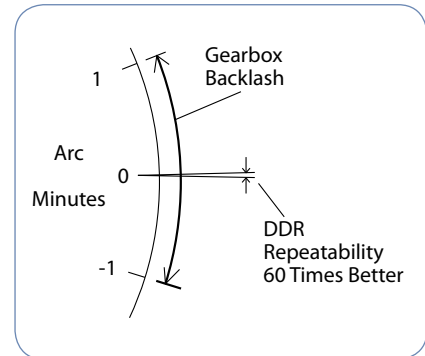

Improved Repeatability

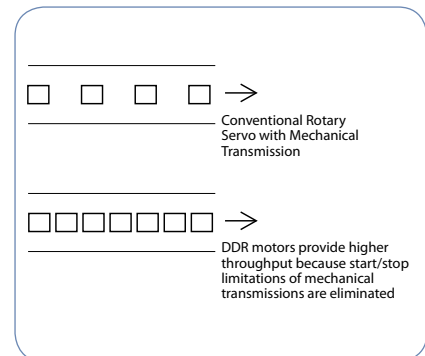

Increased Throughput

## Fewer Parts

With direct drive motors, all you need is the motor and the mounting bolts. This often replaces many parts including brackets, guards, belts, pulleys, tensioners, couplings, and bolts, resulting in:

- Fewer parts on the BOM. Less parts to purchase, schedule, inventory and control, and less parts to assemble.
- Assembly time of the servo drops from several hours with the mechanical transmission to several minutes with the DDR.
- Reduced cost. Although a direct drive motor may carry a small price-premium compared to a motor/gearhead with the same torque, consider that there is an overall cost reduction when eliminating the parts and labor of all the extra components required in a servo system with mechanical transmission.

## No Inertia Matching

Servo systems with mechanical transmissions require inertia matching that limits the reflected load inertia at 5 to 10 times the motor inertia. If this limitation is not met, the system becomes difficult to control due to instability issues. Inertia matching limitations of mechanical transmission systems often force machine designers to use a larger motor than would otherwise be required just to satisfy the inertia matching requirement.

Such sizing conventions are not required with direct drive technology. Since the motor is directly connected to the load, the inertia of the motor and the load become a common inertia. Therefore, no inertia matching is required when using DDR. DDR applications have run with inertia ratios greater than 11,000:1.

## Reduced Audible Noise

Machines with DDR motors have audible noise levels as low as 20 dB less than the same machine with a mechanical transmission.

## Three DDR Product Categories to Choose From

Kollmorgen's 50 years of electromagnetic and electromechanical design experience combined with our quality and service, allowed us to refine and expand DDR technology into three product categories for easy installation, use, and short lead times: [Frameless DDR](#), [Housed DDR](#), and the [Cartridge DDR](#). This allows you to select the right DDR solution for your application.

### F Series Frameless DDR

Frameless motors include a rotor and stator as separate components which are integrated into, ride on the bearings of, and become a part of the driven load. Frameless motors offer the most compact and lightweight DDR solution available. The "F" series is Kollmorgen's latest Frameless DDR product. It provides excellent torque/volume with the use of a proprietary neodymium-iron magnet rotor structure and skewed armature assembly. The F series is the first UL recognized parts set available on the market. This provides OEMs with the benefits of UL component ratings for easier agency approval on their machines.

### Housed DDR

The Housed DDR is a housed motor assembly featuring a factory aligned high-resolution feedback device and precision bearings, allowing it to function as the core of rotary indexing and rate table applications. The system can also be used as a flexible indexer, providing programmable, rapid indexing far exceeding the throughput and accuracy of conventional mechanical or variable reluctance technology indexers.

### Cartridge DDR

This motor is the first in the industry to combine the space-saving and performance advantages of Frameless DDR technology with the ease of installation of a full-frame motor. Consisting of a rotor, stator, and factory-aligned high-resolution feedback device, the motor uses the machine's bearings to support the rotor. An innovative compression coupling engages the rotor to the load and the frame of the mounts to the machine with a bolt circle and pilot diameter just like a conventional servomotor, saving space and design time and simplifying the overall system.

### DDR Applications

Format	Where Used
Frameless DDR	Application where size and weight must be absolutely minimized
Housed DDR	Applications where the load rides on the motor's bearings such as indexing or rate tables
Cartridge DDR	Any application with existing bearings

# Cartridge Direct Drive Rotary (DDR) Motor

The Cartridge Direct Drive Rotary (DDR) Motor is the first in the industry to combine the space-saving and performance advantages of frameless DDR technology with the ease of installation of a full-frame motor. Cartridge DDR motors also feature an advanced electromagnetic design that provides up to 50% more torque density than comparably sized conventional servomotors.

Consisting of a rotor, stator, factory-aligned high-resolution feedback device, the Cartridge DDR motor uses the machine's bearings to support the rotor.

An innovative compression coupling secures the Cartridge DDR's rotor to the machine shaft, and the Cartridge DDR's housing is bolted to the machine frame with a bolt circle and pilot – just like a conventional servomotor – saving space and design time and simplifying the overall system.

Conventional servo systems typically include a number of mechanical transmission components that limit the performance and reliability, and drive up cost of operation. Cartridge DDR motors eliminate all mechanical transmission parts, resulting in the following features:

## Cartridge DDR Features

- Assembles as quickly as 5 minutes
- 5 frame sizes, multiple lengths
- Continuous torque range: 4.57 Nm (3.37 lb-ft) to 510 Nm (373 lb-ft), accommodates a wide range of high-power application requirements
- Optimized torque output with high-pole count efficient electromagnetic design
- Integrated high-resolution sine-encoder
- 134,217,728 counts/rev
- Speeds up to 2,500 RPM meets most medium speed and high-torque application requirements
- Meets high power demands of most frameless motor applications
- Direct load connection eliminates maintenance of gearheads, belts, or pulleys
- Low cogging for smooth low-speed rotation
- Zero backlash and compliance provides more responsive system performance



## The Cartridge DDR Advantage – Press Feed Machine

Consider how Cartridge DDR technology improves a Press Feed machine:

### Reduced Assembly Time

The assembly time for the original mechanical transmission system was 4 hours. In contrast, the Cartridge DDR motor is installed in less than 5 minutes, resulting in a significant cost savings in labor.

### Reduced Parts Count

The original mechanical transmission system comprises 2 bracket pieces, 12 bolts, 2 pulleys, 2 set screws, 2 keys, a timing belt, a housing to protect operators from the timing belt, a tension system for the timing belt, and motor/gearhead. With the Cartridge DDR system, this is all replaced by the motor and 4 mounting bolts, resulting in fewer parts to maintain and cost savings.

### Improved Accuracy

The best planetary gearheads have a backlash between 1 and 2 arc-minutes. Over the life of the gearhead, the backlash will increase. The Cartridge DDR system has an absolute accuracy of 26 arc-seconds and a repeatability of 0.7 arc-seconds. The Press Feed machine with the Cartridge DDR has a feed accuracy of +/- 0.0005 inch where the Press Feed machine with the mechanical transmission has a feed accuracy of 0.002 inch. Therefore, there was an overall four times improvement in machine accuracy with the Cartridge DDR system.

### Increased Throughput

The cycle rate of the Cartridge DDR system is two times better than the mechanical transmission. This results in an increase in throughput of 100 percent.

## Improved Reliability and Simplified Maintenance

The Cartridge DDR system eliminates parts that wear, change over time, or fail. Gearheads are prone to wear, and backlash increases over time. Belts and pulleys stretch and require maintenance to maintain proper belt tension. By eliminating these components, the Cartridge DDR system delivers greater system reliability.

### Press Feed Example

Gearheads have a finite life span, especially in a demanding cyclic application such as a Press Feed. On this machine, the gearhead must be replaced every 10,000 hours and the belt must be tensioned every 2,000 hours. By contrast, the Cartridge DDR motor has no wear components and requires no maintenance thus simplifying the maintenance schedule for the machine, including operating costs.

### Reduced Audible Noise

The Cartridge DDR system has as much as a 20 dB reduction in noise compared to a mechanical transmission servo system. This can dramatically reduce the overall noise level of the machine. A quieter machine gives the perception of quality. This is rightfully so as the noise emitted by gears and belts is caused by the wearing of the parts.

### Total Reduced Cost

A Cartridge DDR motor typically costs 20 percent more than a comparable motor/gearhead combination. However, the elimination of parts and assembly time typically results in a lower total cost for the Cartridge DDR solution.



Press feed machine built with a conventional servomotor, gearhead, belt and pulleys.



Same machine with a Cartridge DDR motor installed. Here, the shaft of the driven roll is extended into the Cartridge DDR motor and the motor applies torque directly to the driven roll.



# Cartridge Direct Drive Rotary Motor (DDR)

## 240 Vac Performance Data

Cartridge Motor	AKD Drive	Frame Size	Continuous Torque	Peak Torque	Maximum Speed	Weight	Inertia (Jm)
		mm (in)	Nm (lb-in)	Nm (lb-in)	RPM	kg (lb)	kg-cm <sup>2</sup> (lb-in-s <sup>2</sup> x10 <sup>-3</sup> )
C041A	AKD-X00306	108 (4.25)	4.57 (40.4)	12.3 (109)	1750	4.08 (9.00)	5.86 (5.19)
C041B	AKD-X00606	108 (4.25)	4.52 (40.0)	12.2 (108)	2500	4.08 (9.00)	5.86 (5.19)
C042A	AKD-X00606	108 (4.25)	8.25 (73.0)	22.2 (196)	1700	5.67 (12.5)	8.87 (7.85)
C042B	AKD-X01206	108 (4.25)	8.45 (74.8)	22.8 (202)	2500	5.67 (12.5)	8.87 (7.85)
C043A	AKD-X00606	108 (4.25)	11.1 (98.2)	30.0 (265)	1250	7.26 (16.0)	11.9 (10.5)
C043B	AKD-X01206	108 (4.25)	11.2 (99.1)	30.2 (267)	2500	7.26 (16.0)	11.9 (10.5)
C044A	AKD-X00606	108 (4.25)	13.9 (123)	37.4 (331)	1050	8.84 (19.5)	14.9 (13.2)
C044B	AKD-X01206	108 (4.25)	14.1 (125)	37.9 (335)	2150	8.84 (19.5)	14.9 (13.2)
C051A	AKD-X00606	138 (5.43)	11.7 (104)	30.2 (267)	1200	8.39 (18.5)	27.4 (24.2)
C051B	AKD-X01206	138 (5.43)	11.9 (105)	30.6 (271)	2450	8.39 (18.5)	27.4 (24.2)
C052C	AKD-X00606	138 (5.43)	16.9 (150)	43.1 (381)	950	10.7 (23.5)	35.9 (31.8)
C052D	AKD-X01206	138 (5.43)	16.5 (146)	42.3 (374)	2050	10.7 (23.5)	35.9 (31.8)
C053A	AKD-X01206	138 (5.43)	21.0 (186)	54.1 (479)	1350	13.2 (29.0)	44.3 (39.2)
C053B	AKD-X02406	138 (5.43)	20.2 (179)	50.1 (443)	2500	13.2 (29.0)	44.3 (39.2)
C054A	AKD-X01206	138 (5.43)	24.9 (220)	63.8 (565)	1200	15.4 (34.0)	52.8 (46.7)
C054B	AKD-X02406	138 (5.43)	23.8 (211)	61.2 (542)	2500	15.4 (34.0)	52.8 (46.7)
C061A	AKD-X01206	188 (7.40)	33.8 (299)	86.8 (768)	900	18.6 (41.0)	94.1 (83.2)
C061B	AKD-X02406	188 (7.40)	32.6 (288)	75.6 (669)	1950	18.6 (41.0)	94.1 (83.2)
C062C	AKD-X01206	188 (7.40)	48.4 (428)	117 (1040)	700	23.6 (52.0)	126 (112)
C062B	AKD-X02406	188 (7.40)	44.6 (395)	102 (900)	1400	23.6 (52.0)	126 (112)
C063C	AKD-X01206	188 (7.40)	61.8 (547)	157 (1380)	550	29.0 (63.0)	157 (139)
C063B	AKD-X02406	188 (7.40)	59.0 (522)	136 (1200)	1050	29.0 (63.0)	157 (139)
C091A	AKD-X02406	246 (9.68)	50.2 (444)	120 (1060)	600	27.7 (61.0)	280 (248)
C092C	AKD-X02406	246 (9.68)	102 (900)	231 (2050)	450	41.3 (91.0)	470 (416)
C093C	AKD-X02406	246 (9.68)	139 (1230)	317 (2800)	350	54.4 (120)	660 (584)
C131C	AKD-X02406	350 (13.8)	189 (1670)	395 (3500)	250	63.5 (140)	1240 (1100)
C131B	AKD-X04806*	350 (13.8)	190 (1680)	396 (3500)	450	63.5 (140)	1240 (1100)
C132C	AKD-X02406	350 (13.8)	362 (3200)	818 (7240)	120	101 (223)	2250 (1990)
C132B	AKD-X04806*	350 (13.8)	361 (3190)	759 (6720)	225	101 (223)	2250 (1990)
C133C	AKD-X02406	350 (13.8)	499 (4410)	1070 (9890)	100	132 (292)	3020 (2670)
C133B	AKD-X04806*	350 (13.8)	510 (4510)	1090 (9700)	175	132 (292)	3020 (2670)

## 400/480 Vac Systems Performance Data

Cartridge Motor	AKD Drive	Frame Size	Continuous Torque	Peak Torque	Maximum Speed		Weight	Inertia (Jm)
		mm (in)	Nm (lb-in)	Nm (lb-in)	RPM		kg (lb)	kg-cm <sup>2</sup> (lb-in-s <sup>2</sup> x10 <sup>-3</sup> )
					400 Vac	480 Vac		
CH041A	AKD-X00307	108 (4.25)	4.56 (40.4)	11.3 (100)	2500	2500	4.08 (9.00)	5.86 (5.19)
CH042A	AKD-X00607	108 (4.25)	8.26 (73.1)	19.0 (168)	2500	2500	5.67 (12.5)	8.87 (7.85)
CH043A	AKD-X00607	108 (4.25)	11.1 (98.2)	25.3 (224)	2250	2500	7.26 (16.0)	11.9 (10.5)
CH044A	AKD-X00607	108 (4.25)	13.9 (123)	31.6 (280)	1850	2250	8.84 (19.5)	14.9 (13.2)
CH051A	AKD-X00607	138 (5.43)	11.7 (104)	28.0 (248)	2100	2500	8.39 (18.5)	27.4 (24.2)
CH052C	AKD-X00607	138 (5.43)	16.9 (150)	43.1 (381)	1750	2100	10.7 (23.5)	35.9 (31.8)
CH053A	AKD-X01207	138 (5.43)	21.0 (186)	54.1 (479)	2350	2500	13.2 (29.0)	44.3 (39.2)
CH054A	AKD-X01207	138 (5.43)	24.9 (220)	63.8 (565)	2100	2500	15.4 (34.0)	52.8 (46.7)
CH061A	AKD-X01207	188 (7.40)	33.8 (299)	86.8 (768)	1600	1900	18.6 (41.0)	94.1 (83.2)
CH062C	AKD-X01207	188 (7.40)	48.4 (428)	117 (1040)	1250	1550	23.6 (52.0)	126 (112)
CH063C	AKD-X01207	188 (7.40)	61.8 (547)	157 (1380)	950	1150	29.0 (63.0)	157 (139)
CH063B	AKD-X02407	188 (7.40)	59.0 (522)	136 (1200)	1850	2200	29.0 (63.0)	157 (139)
CH091A	AKD-X02407	246 (9.68)	50.2 (444)	120 (1060)	1200	1500	27.7 (61.0)	280 (248)
CH092C	AKD-X02407	246 (9.68)	102 (900)	231 (2050)	800	1000	41.3 (91.0)	470 (416)
CH093C	AKD-X02407	246 (9.68)	139 (1230)	317 (2800)	700	800	54.4 (120)	660 (584)
CH131C	AKD-X02407	350 (13.8)	189 (1670)	395 (3500)	500	600	63.5 (140)	1240 (1100)
CH131B	AKD-X04807*	350 (13.8)	190 (1680)	396 (3500)	800	1000	63.5 (140)	1240 (1100)
CH132C	AKD-X02407	350 (13.8)	362 (3200)	818 (7240)	250	300	101 (223)	2250 (1990)
CH132B	AKD-X04807*	350 (13.8)	361 (3190)	759 (6720)	400	500	101 (223)	2250 (1990)
CH133C	AKD-X02407	350 (13.8)	499 (4410)	1070 (9480)	200	250	132 (292)	3020 (2670)
CH133B	AKD-X04807*	350 (13.8)	510 (4510)	1090 (9700)	350	400	132 (292)	3020 (2670)

Note 1: Refer to page 62 for matching cables.

Note 2: For complete AKD and Cartridge DDR Motor model nomenclature, refer to pages 63 and 65 respectively.

\*Available in 2010.

### Cartridge DDR C04, C05 and C06 Dimensions

Cartridge Motor	A mm (in)	B mm (in)	C mm (in)	D mm (in)
C(H)041	171 (6.73)	108 (4.25)	59 (2.31)	93 (3.67)
C(H)042	202 (7.95)	108 (4.25)	59 (2.31)	93 (3.67)
C(H)043	233 (9.17)	108 (4.25)	59 (2.31)	93 (3.67)
C(H)044	264 (10.4)	108 (4.25)	59 (2.31)	93 (3.67)
C(H)051	195 (7.68)	138 (5.43)	76 (3.00)	108 (4.25)
C(H)052	220 (8.66)	138 (5.43)	76 (3.00)	108 (4.25)
C(H)053	245 (9.65)	138 (5.43)	76 (3.00)	108 (4.25)
C(H)054	270 (10.6)	138 (5.43)	76 (3.00)	108 (4.25)
C(H)061	226 (8.90)	188 (7.40)	99 (3.88)	133 (5.25)
C(H)062	260 (10.2)	188 (7.40)	99 (3.88)	133 (5.25)
C(H)063	294 (11.6)	188 (7.40)	99 (3.88)	133 (5.25)

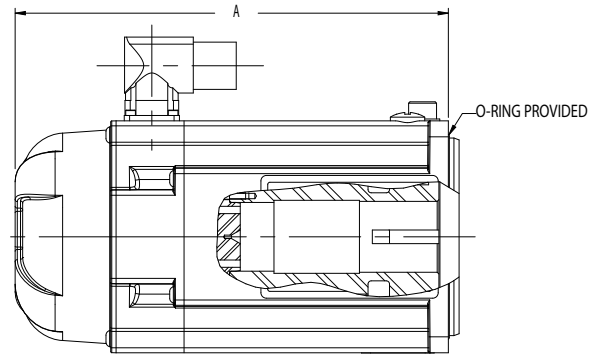
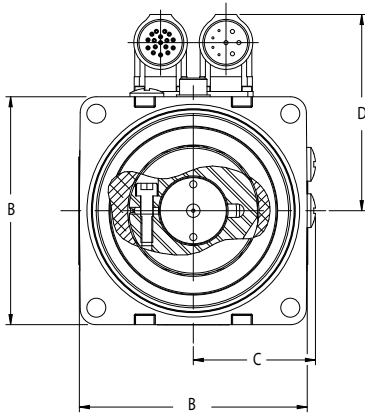

### Cartridge DDR C09 and C13 Dimensions

Cartridge Motor	A mm (in)	B mm (in)	C mm (in)	D mm (in)
C(H)091	204 (8.03)	246 (9.68)	149 (5.88)	182 (7.18)
C(H)092	253 (9.96)	246 (9.68)	149 (5.88)	182 (7.18)
C(H)093	302 (11.9)	246 (9.68)	149 (5.88)	182 (7.18)
C(H)131	231 (9.09)	350 (13.8)	200 (7.87)	256 (10.1)
C(H)132	301 (11.9)	350 (13.8)	200 (7.87)	256 (10.1)
C(H)133	370 (14.6)	350 (13.8)	200 (7.87)	256 (10.1)

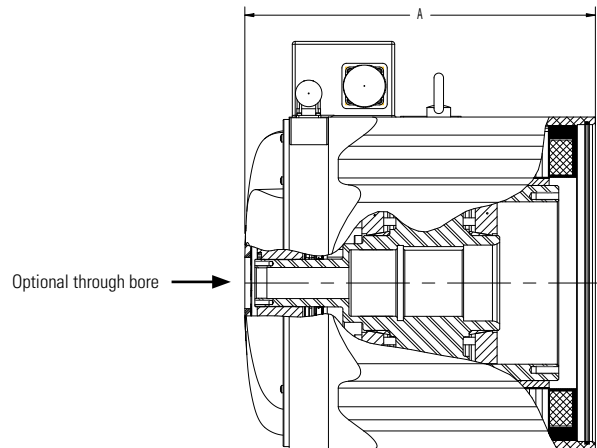
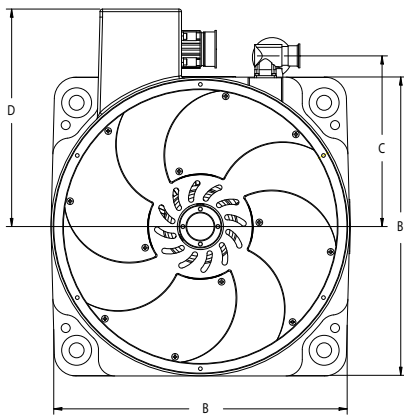

# Housed Direct Drive Rotary (DDR) Motor

Housed DDR motors are multi-pole (16 to 32) hollow shaft motors with their own bearings and high-resolution encoder system. They are coupled directly to the load and enable very precise and repeatable systems. Housed DDR motors are maintenance free and run more quietly and with better dynamics than systems that use gears, belts, cams or other mechanical transmission components.

## DDR Features

- 4 frame sizes
- Robust cross-roller bearing
- Dual bearing option
- IP67 option
- Continuous torque range: 5.8 Nm (4.3 lb-ft) to 339 Nm (250 lb-ft)
- Optimized torque output with high-pole count efficient electromagnetic design
- Integrated high-resolution sine-encoder
- 134,217,728 counts per rev resolution, 27 bits
- Feedback accuracy: +/- 26 arc-sec

## Benefits

- Transmission elements such as couplings, toothed belts, spindles, and other fitted components can be eliminated
- Mechanical design is made much simpler
- Power transmission without backlash
- More compact machinery assemblies
- Increased performance for the entire system

## Housed DDR Advantage

Consider how a Housed DDR motor improved a medical manufacturing machine.

Product is located at the steel pins on the outside of the machine's turret as shown. The 115 kg load wheel has an inertia of 20 kg-m<sup>2</sup>. There are 96 steel pins for an index angle of 3.5 degrees to move.

**The move is accomplished in less than 100  $\mu$ s.**

## Realized Housed DDR Benefits

### The Direct Drive Advantage

The following improvements were observed compared to the previous design that used a mechanical indexer:

### Improved Repeatability

The Housed DDR demonstrated a repeatability better than 1 arc-second which was substantially better than the mechanical indexer.

### No Degradation

Direct Drive system performance, accuracy and repeatability do not degrade over time as they do with a mechanical indexer. With a mechanical indexer, as parts wear over time, the accuracy and repeatability degrade.

### Immediate Stop

The direct drive system can immediately stop if there is a process error. The mechanical indexer required several cycles to stop which could cause tooling and machine damage.



### Greatly Reduced Audible Noise

With the mechanical indexer, the noise was at a level such that two people would have to yell to hear each other. By contrast, if you turned your back to the Housed DDR, you could barely detect that it was running.

### Easy Profile Change

Motion parameters such as index angle, speed, acceleration, and dwell are very simple to change with the Housed DDR. The mechanical indexer does not support flexible motion profiles.

### Better Value

The Housed DDR is attractively priced compared to the mechanical indexer it replaced. When the other advantages listed above are also considered, the Housed DDR was the obvious choice.

### 240 Vac Performance Data

DDR Motor	AKD Drive	Frame Size mm (in)	Continuous Torque Nm (lb-in)	Peak Torque Nm (lb-in)	Maximum Speed (RPM)	Weight kg (lb)	Inertia (Jm) cm <sup>2</sup> (lb-in-s <sup>2</sup> x10 <sup>-3</sup> )
D061	AKD-X00606	175 (6.90)	5.3 (46.9)	16.9 (150)	500	9.4 (20.7)	61 (54.0)
D062	AKD-X00606	175 (6.90)	9.8 (86.7)	33.5 (296)	500	11.3 (24.9)	71 (62.8)
D063	AKD-X00606	175 (6.90)	17.7 (157)	64.4 (570)	500	13.8 (30.4)	86 (76.1)
D081	AKD-X00606	217 (8.55)	15.9 (141)	45.0 (398)	500	17.9 (39.4)	144 (127)
D082	AKD-X00606	217 (8.55)	25.9 (229)	92.2 (816)	300	21.5 (47.3)	194 (172)
D083	AKD-X00606	217 (8.55)	50.4 (446)	160 (1420)	250	28.8 (63.4)	301 (266)
D101	AKD-X00606	280 (11.0)	34.6 (306)	129 (1140)	300	31.5 (69.3)	693 (613)
D102	AKD-X00606	280 (11.0)	63.4 (561)	227 (2010)	200	43.8 (96.4)	992 (878)
D103	AKD-X01206	280 (11.0)	115 (1020)	501 (4430)	120	60.8 (134)	1750 (1550)
D141	AKD-X01206	362 (14.2)	108 (956)	367 (3250)	200	59.4 (131)	1630 (1440)
D142	AKD-X01206	362 (14.2)	183 (1620)	519 (4590)	120	86.6 (191)	2740 (2430)
D143	AKD-X02406*	362 (14.2)	339 (3000)	1340 (11,900)	60	146 (321)	5420 (4800)

### 400/480 Vac Performance Data

DDR Motor	AKD Drive	Frame Size mm (in)	Continuous Torque Nm (lb-in)	Peak Torque Nm (lb-in)	Maximum Speed RPM	Weight kg (lb)	Inertia (Jm) cm <sup>2</sup> (lb-in-s <sup>2</sup> x10 <sup>-3</sup> )
DH061	AKD-X00607	175 (6.90)	5.3 (46.9)	16.9 (150)	800	9.4 (20.7)	61 (54.0)
DH062	AKD-X00607	175 (6.90)	9.8 (86.7)	33.5 (296)	800	11.3 (24.9)	71 (62.8)
DH063	AKD-X00607	175 (6.90)	17.7 (157)	64.4 (570)	800	13.8 (30.4)	86 (76.1)
DH081	AKD-X00607	217 (8.55)	15.9 (141)	45.0 (398)	500	17.9 (39.4)	144 (127)
DH082	AKD-X00607	217 (8.55)	25.9 (229)	92.2 (816)	500	21.5 (47.3)	194 (172)
DH083	AKD-X00607	217 (8.55)	50.4 (446)	160 (1420)	500	28.8 (63.4)	301 (266)
DH101	AKD-X00607	280 (11.0)	34.6 (306)	129 (1140)	300	31.5 (69.3)	693 (613)
DH102	AKD-X00607	280 (11.0)	63.4 (561)	227 (2010)	300	43.8 (96.4)	992 (878)
DH103	AKD-X01207	280 (11.0)	115 (1020)	501 (4430)	250	60.8 (134)	1750 (1550)
DH141	AKD-X01207	362 (14.2)	108 (956)	367 (3250)	300	59.4 (131)	1630 (1440)
DH142	AKD-X01207	362 (14.2)	183 (1620)	519 (4590)	300	86.6 (191)	2740 (2430)
DH143	AKD-X02407*	362 (14.2)	339 (3000)	1340 (11,900)	120	146.0 (321)	5420 (4800)

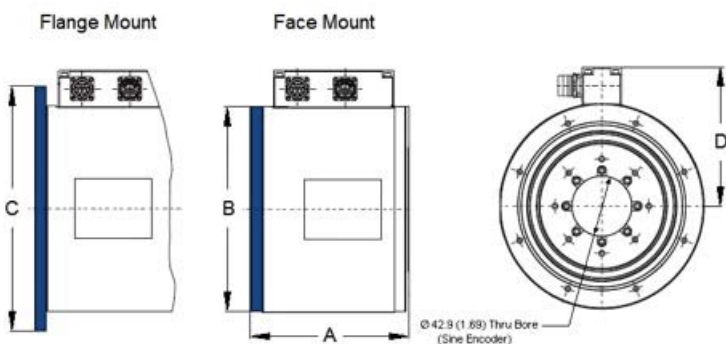

### Dimensions

DDR	A mm (in)	B mm (in)	C mm (in)	D mm (in)
D(H)061	130 (5.12)	175 (6.90)	220 (8.66)	126 (4.95)
D(H)062	140 (5.55)	175 (6.90)	220 (8.66)	126 (4.95)
D(H)063	164 (6.46)	175 (6.90)	220 (8.66)	126 (4.95)
D(H)081	145 (5.71)	217 (8.55)	260 (10.2)	147 (5.80)
D(H)082	165 (6.50)	217 (8.55)	260 (10.2)	147 (5.80)
D(H)083	206 (8.11)	217 (8.55)	260 (10.2)	147 (5.80)
D(H)101	153 (6.02)	280 (11.0)	330 (13.0)	181 (7.11)
D(H)102	185 (7.28)	280 (11.0)	330 (13.0)	181 (7.11)
D(H)103	248 (9.76)	280 (11.0)	330 (13.0)	181 (7.11)
D(H)141	153 (6.02)	362 (14.2)	406 (16.0)	218 (8.59)
D(H)142	217 (8.52)	362 (14.2)	406 (16.0)	218 (8.59)
D(H)143	344 (13.50)	362 (14.2)	406 (16.0)	218 (8.59)

Note 1: Refer to page 62 for matching cables. \* Available in 2010.

Note 2: For complete AKD and Housed DDR Motor model nomenclature, refer to pages 63 and 66 respectively.

# Linear Positioning Systems

Kollmorgen is also the market leader in precise linear positioning, backed by 40 years of experience of providing innovative solutions customers can count on everyday. We offer Linear Positioners that range from 20 N (5 lb) of thrust and 100 mm (4 in) length, up to 25 kN (5600 lb) and 1.5 m length (unlimited length for linear motors) with precision better than a single thread of human hair ( $\leq 0.1$  mm/0.004 in)

## Electric Cylinders (EC)

Primarily designed to apply a force through an extendable rod, Electric Cylinders are a clean and efficient replacement for hydraulic actuators and pneumatic cylinders, and an alternative to many types of linear transmissions. A wide variety of mounting and coupling alternatives significantly increases their problem solving potential.



*Electric Cylinders*

## Rodless Actuators

Long travel, quiet operation, and high moment loading differentiates Rodless Actuators from other mechanical transmissions.



*Rodless Actuators*

## Precision Tables

Positioning Tables are used when accurate and repeatable motion is critical (1 part per 10,000 or better). These tables offer a wide variety of single and multi-axis configurations, open and closed frame tables, ball or lead screw driven, and overhung and constant support Kollmorgen geometry configurations.



*Precision Tables*

## Direct Drive Linear (DDL)

Directly coupling a linear motor to the driven load offers many advantages, including eliminating all mechanical transmissions, such as ball/lead screws, rack & pinions, belts/pulleys, and eliminating gearboxes. This in turn also eliminates backlash and compliance, and other problems associated with these mechanicals transmissions.



*Direct Drive Linear Motors*

## DDL Benefits

- Zero maintenance
- No ball screws, gearboxes, rack and pinions, belts/pulleys
- Zero backlash and compliance
- High stiffness
- High positional accuracy
- Compact mechanical assembly
- Reduced parts count in machine
- Very smooth velocity
- Quiet operation

## Performance Data

	Minimum Stroke mm (in)	Maximum Stroke mm (in)	Repeatability mm (in)	Maximum Thrust kN (lbf)	Maximum Payload kN (lbf)	Maximum Speed mm/s (in/s)
Electric Cylinders	50 (2.0)	1500 (60)	0.013 (0.0005)	25 (5620)	Designed to push and pull	1300 (51)
Rodless Actuators	150 (6.0)	2700 (106)	0.1 (0.004)	3.1 (700)	1.33 (300)	3000 (120)
Precision Tables	50 (2.0)	1500 (60)	0.004 (0.00016)	2.0 (440)	6.2 (1400)	1300 (51)
Direct Drive Linear Motors*	64 (2.5)	Unlimited	$1 \times 10^{-6}$ ( $3.9 \times 10^{-8}$ )	15.6 (3500)	Customer design limited	5000 (200)

\* We offer hundreds of custom and semi-custom solutions for Direct Drive Linear (DDL) applications.

# Precision Tables DS4 / DS6 Series

Precision Positioning Tables are best suited for applications where the accuracy and repeatability requirements are more important than axial thrust of the drive train. Precision Positioning Tables can also be used in less precise applications where adequate moment load support is necessary, and are ideal building blocks for complete multi-axis positioning systems.

The DS4 and DS6 are Kollmorgen's most versatile and modular line of positioning tables.

## Combined with the AKD Drive and AKM Motors, DS4 and DS6 Systems Offer

- An optimized electromechanical solution suitable for demanding high precision positioning
- Performance and versatility in a compact package
- Outstanding industrial durability
- Tremendous configuration flexibility
- Industry-leading price vs. performance value

## DS Series Design Features

Following are several features that make the DS Series the positioning table of choice for the most demanding applications.

- Travel lengths from 50 mm to 2 m cover a wide range of applications.
- Precision ballscrew drive, with 5 mm, 10 mm and 25 mm leads, offers high speed and efficiency, excellent repeatability and accuracy, and mechanical advantage.
- Proven magnetic stainless steel seal strip technology effectively seals the internal components of the DS Series, protecting the ballscrew and ways from contaminants. This feature also contains ballscrew and way lubrication within the DS Series.
- Easily configurable modular design and option set, including a variety of motor mounting orientations, motor sizes and type, ballscrew leads, coupling types and sizes, encoder feedback options, limit/home sensor types, and shaft brakes allow the DS Series to be customized to meet your specific requirements.

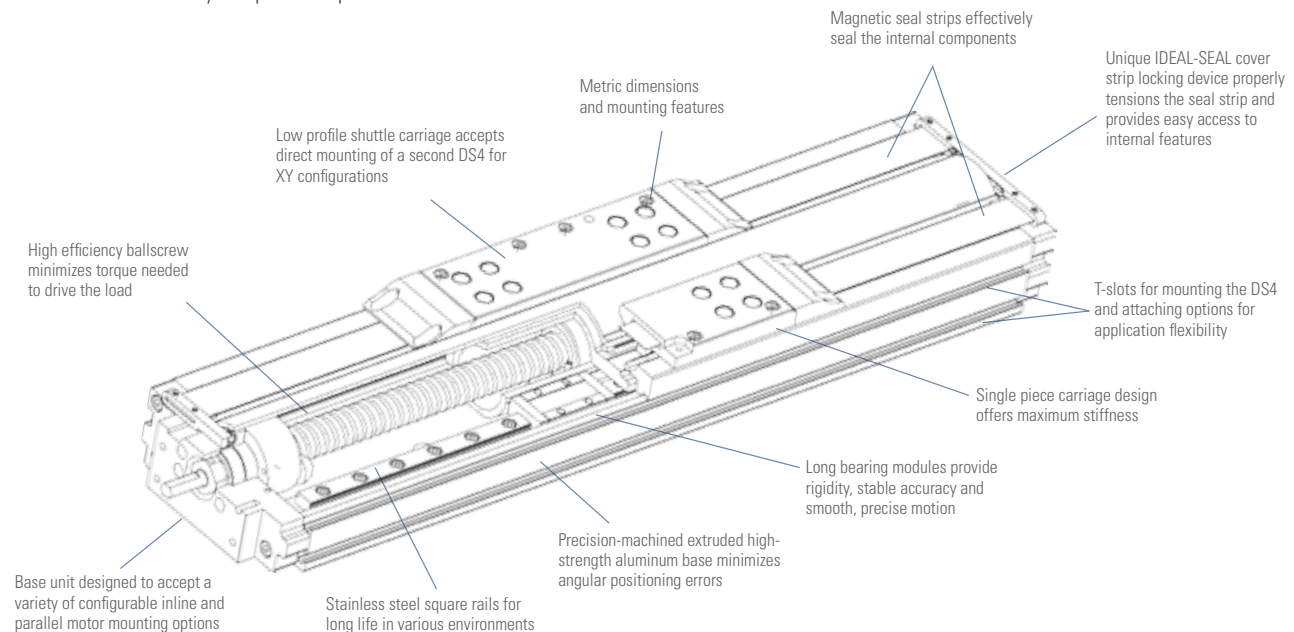



DS Series Precision Tables can be ordered in a variety of multi-axis configurations including XY, XZ, and XYZ or cartesian arrangements. Consult Kollmorgen applications engineering for standard and custom configurations.

A second option is to order standard multi-axis brackets and assemble the axes yourself.



All DS4 and DS6 tables will bolt directly together in a standard XY without modification.

### Unique IDEAL-SEAL Magnetic Cover Strip Locking Device

- Entire length of lead screw and linear bearing system are protected, providing both operator safety and protection from contaminants.
- Seal strips are always properly tensioned, drastically decreasing wear that requires regular field repair.
- Allows easy access to interior of DS4 for mounting and maintenance.
- No small hardware or springs to lose, and no exposure to the sharp ends of the strips, which are problems for similar seal end-cap designs.

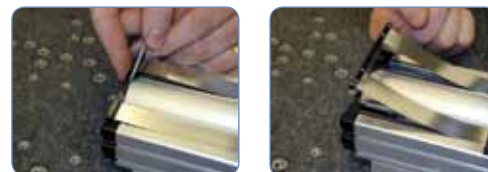

### Configurable Options

DS Series	
Servomotor Options	AKM23D, AKM42G
Grades	Precision (up to 600 mm), Commercial
Motor Orientations	In-line, Parallel Right/Left/Under
Couplings Options (inline configurations)	Bellows, Oldham
Transmission Ratio (parallel configurations)	1:1
Limit Sensors	PNP (sinking) Inductive Proximity Sensors, 5-30 Vdc
Home Sensor	PNP (sinking) Inductive Proximity Sensors, 5-30 Vdc
Shaft Brake	Electromagnetic Power of Holding Brake, 24 Vdc
Linear Encoder Options	1.0, 0.5 and 0.1 motion resolution, modular incremental type



Limit Sensor



Linear Encoder

### Accessories

DS Series	
Toe Clamps	Provide convenient external mounting to a base plate or to riser blocks
Narrow Riser Blocks	Raise unit for clearance of larger motor options, utilizing internal base mounting features on the side
Wide Riser Blocks	Allow rising of the unit, independent of base mounting features
Brackets and Mounting Plates	Facilitate multi-axis configurations
Cable Sets	For connection to AKD and other drives



Toe Clamp



# Precision Tables DS4 / DS6 Series

## DS4 General Specifications

Travel (mm)	50	100	150	200	250	300	350	400	450	500	550	600	
Overall Height, less motor (mm)	47												
Width (mm)	95												
System Length, Inline less motor (mm)	317	367	417	467	517	567	617	667	717	767	817	867	
System Length, Parallel motor mounts (mm)	300	350	400	450	500	550	600	650	700	750	800	850	
Positional Accuracy (microns)													
Commercial Grade	12	12	14	20	22	24	26	26	28	34	36	40	
Precision Grade	8	8	10	12	12	14	14	16	19	21	23	25	
Straightness & Flatness (microns)	6	6	9	12	12	14	18	21	23	23	25	25	
Bi-directional Repeatability, open loop													
Commercial Grade (microns)	+/- 3												
Precision Grade (microns)	+/- 1.3												
Load Capacity, Normal (kg) (max)	170												
Axial Load Capacity (kg)	90												
Acceleration (max) (m/sec <sup>2</sup> )	20												
Moving Mass (kg)	0.75												
Total Mass (kg)	2.7	3	3.3	3.6	3.9	4.1	4.4	4.7	5	5.3	5.6	5.9	
Ballscrew Diameter (mm)	16												
Duty Cycle (%)	100												
Ballscrew Efficiency	90												
Max. Breakaway Torque (oz-in)	18												
Max. Running Torque (oz-in)	16												
Ballscrew Lead Available (mm)	5, 10												
Input Inertia (10 <sup>-5</sup> kg-m <sup>2</sup> )	1.17	1.24	1.67	1.93	2.18	2.43	2.68	2.93	3.19	3.44	3.69	3.94	
Max. Ballscrew Speed (rev/sec)	80						60		55		50		

## DS6 General Specifications

Travel (mm)	100	200	300	400	500	600	700	800	900	1000	1250	1500	1750	2000										
Overall Height (mm)	70																							
Width (mm)	150																							
System Length, Inline less motor (mm)	465	565	665	765	865	965	1065	1165	1265	1365	1615	1865	2115	2365										
System Length, Parallel motor mounts (mm)	470	570	670	770	870	970	1070	1170	1270	1370	1620	1870	2120	2370										
Positional Accuracy (microns)																								
Commercial Grade	14	22	28	39	45	48	92	94	103	105	118	134	154	159										
Precision Grade	12	14	15	20	25	50	-	-	-	-	-	-	-	-										
Straightness & Flatness (microns)	10	14	17	23	30	33	40	46	50	55	76	95	115	135										
Bi-directional Repeatability, open loop																								
Commercial Grade (microns)	+/- 3						+/-5																	
Precision Grade (microns)	+/- 1.3						N/A																	
Load Capacity, Normal (kg) (max)	630																							
Axial Load Capacity (kg)																								
Commercial Grade	90						200																	
Precision Grade	90						N/A																	
Acceleration (max) (m/sec <sup>2</sup> )	20																							
Moving Mass (kg)	2.8																							
Total Mass (kg)	8.9	10.2	11.5	12.8	14.0	15.4	19.4	20.9	22.4	23.9	27.8	31.6	35.4	40.1										
Ballscrew Diameter (mm)	16										25													
Duty Cycle (%)	100																							
Ballscrew Efficiency	90						80																	
Max. Breakaway Torque (oz-in)	18						55																	
Max. Running Torque (oz-in)	16						48																	
Ballscrew Lead Available (mm)	5, 10						5, 10, 25																	
Input Inertia (10 <sup>-5</sup> kg-m <sup>2</sup> )	3.8	4.4	5	5.5	6.1	6.7	37	40.4	43.9	47.3	56	64.5	73.2	81.9										
Max. Ballscrew Speed (rev/sec)	80				60		50		60		50		40		35		24		16		13		11	

\*All performance specifications are based upon proper mounting procedures, with the DS Table fully supported on a flat surface (flat within 0.008 mm/300 mm). Positional accuracy and repeatability specifications are for inline motor mount models only. Contact customer service for specifications of parallel mount configurations. Above specifications are measured 37.5 mm directly above the center of the carriage. Specifications are based upon operation at 20° C.

### 120 Vac Performance Data

	Sys #	Precision Table - AKM Servomotor	AKD Drive	Stroke Length Type	Cont. Thrust @ Speed (lb @ in/sec)		Peak Thrust @ Speed (lb @ in/sec)		Max Thrust (lb)	Max System Speed (in/sec)	Max Stroke for Max Speed (mm)
DS4	1	DS4-XXX-10G-AKM23D-■■■■	AKD-X00306	≤ 600 mm	94	17.6	210	10.8	210	17.6	600
	2	DS4-XXX- 5G-AKM23D-■■■■	AKD-X00306	≤ 600 mm	176	8.8	210	8.4	210	8.8	600
DS6	3	DS6-XXX-25G-AKM23D-■■■■	AKD-X00306	≤ 600 mm	37	44.0	138	8.2	138	44.0	600
	4	DS6-XXX-10G-AKM23D-■■■■	AKD-X00306	≤ 600 mm	94	17.6	210	10.8	210	17.6	600
	5	DS6-XXX- 5G-AKM23D-■■■■	AKD-X00306	≤ 600 mm	176	8.8	210	8.4	210	8.8	600
DS6	6	DS6-XXX-25G-AKM23D-■■■■	AKD-X00306	≥ 700 mm	37	44.0	138	8.2	138	44.0	800
	7	DS6-XXX-10G-AKM23D-■■■■	AKD-X00306	≥ 700 mm	82	17.6	331	3.3	332	17.6	800
	8	DS6-XXX- 5G-AKM23D-■■■■	AKD-X00306	≥ 700 mm	128	8.8	440	4.4	440	8.8	800

### 240 Vac Performance Data

	Sys #	Precision Table - AKM Servomotor	AKD Drive	Stroke Length Type	Cont. Thrust @ Speed (lb @ in/sec)		Peak Thrust @ Speed (lb @ in/sec)		Max Thrust (lb)	Max System Speed (in/sec)	Max Stroke for Max Speed (mm)
DS4	1	DS4-XXX-10G-AKM23D-■■■■	AKD-X00306	≤ 600 mm	88	31.5	210	30	210	31.5	300
	2	DS4-XXX- 5G-AKM23D-■■■■	AKD-X00306	≤ 600 mm	165	15.7	210	15.7	210	15.7	300
DS6	3	DS6-XXX-10G-AKM23D-■■■■	AKD-X00306	≤ 600 mm	90	31.5	210	30	210	31.5	300
	4	DS6-XXX- 5G-AKM23D-■■■■	AKD-X00306	≤ 600 mm	165	15.7	210	15.7	210	15.7	300
	5	DS6-XXX-25G-AKM23D-■■■■	AKD-X00306	≥ 700 mm	34	59	137	48	137	59	700
	6	DS6-XXX-10G-AKM23D-■■■■	AKD-X00306	≥ 700 mm	79	23.6	331	19.3	332	23.6	700
	7	DS6-XXX- 5G-AKM23D-■■■■	AKD-X00306	≥ 700 mm	126	11.8	440	11.8	440	11.8	700
	8	DS6-XXX-10G-AKM42G-■■■■	AKD-X00306	≤ 600 mm	210	28.4	210	28.4	210	28.4	300
	9	DS6-XXX- 5G-AKM42G-■■■■	AKD-X00306	≤ 600 mm	210	14.5	210	14.5	210	14.5	300
	10	DS6-XXX-25G-AKM42G-■■■■	AKD-X00306	≥ 700 mm	102	59	393	36	399	59	700
	11	DS6-XXX-10G-AKM42G-■■■■	AKD-X00306	≥ 700 mm	245	23.6	440	23.6	440	23.6	700
	12	DS6-XXX- 5G-AKM42G-■■■■	AKD-X00306	≥ 700 mm	440	11.8	440	11.8	440	11.8	700

Note 1: Performance based on inline motor configuration.

Note 2: Refer to page 62 for matching cables.

Note 3: For complete AKD and DS4 / DS6 Series model nomenclature, refer to pages 63 and 67 respectively.

# Electric Cylinders N2 / EC Series

Electric Cylinders are thrust-producing devices that are best suited for applications requiring high axial force with the moment and side loads already properly supported.

Kollmorgen has combined the broad product offering of the N2 and EC Series Electric Cylinders with the industry-leading AKM Servomotors and AKD drives. The N2 and EC Series of electric cylinders offer a wide range of available thrusts in standard units from 600 lb (N2) to 5620 lb (EC5) across 5 electric cylinder frame sizes.

- Speeds up to 52 in/sec are available and integrated geared options provide the ability to increase thrust capacity for lower speed applications, leveraging the speed capacity of servo systems.
- Multiple servomotor options are available for the product line ranging from NEMA 23 size to NEMA 42 size servos. The combination with the AKM Servomotor enables the use of various feedback devices including sine-encoder and the low-cost but high-performance Smart Feedback Device (SFD) when used with the AKD drive.
- Windings and voltage operation are not differentiated in MOTIONEERING®. All systems are offered at all voltages (240, 400, 480).
- The AKM Servomotor comes mounted on the electric cylinder as specified by the electric cylinder part number. This eliminates time to match the motor to the electric cylinder and eliminates potential mechanical incompatibility.

## EC Servo Positioners

- Designed for performance
- Highest quality precision rolled ballscrews and Acme screws – for quiet, long-life operation
- Brushless servo with encoder, resolver or SFD feedback
- Sealed for IP54 protection. IP65 option available
- Thrust up to 25,000 N [5,620 lb]
- Speed up to 1.3 m/s [52.5 in/sec]
- Metric design (ISO 6431)
- Available in 5 power ranges – EC1, 2, 3, 4 & 5

## N2 Servo Positioners

- Smallest package size
- Time-proven design
- Improved durability over previous designs
- Thrust up to 2,670 N [600 lb]
- Speed up to 0.76 m/s [30 in/sec]
- English dimensions (to NFPA standards)
- Brushless servo with encoder, resolver or SFD feedback

## Typical Construction (EC2 cut-away shown)

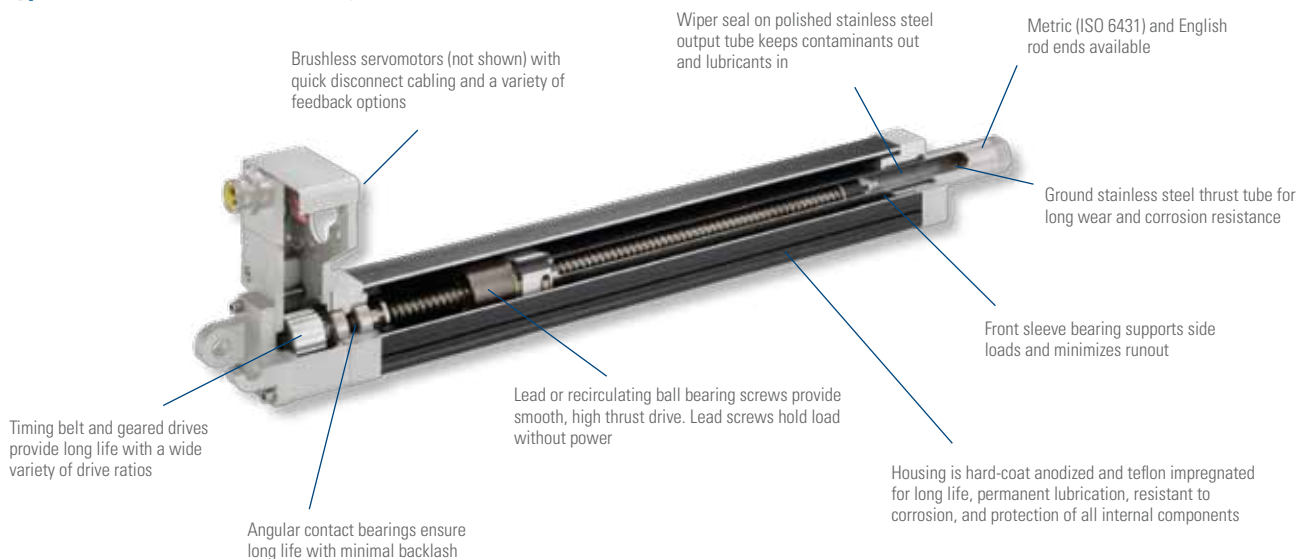

**Kollmorgen offers electric cylinder drive mechanisms designed around either lead or ballscrews.** Ballscrews, being the more efficient of the two, utilize ball nuts riding on recirculating ball bearings, resulting in higher speeds, loads and cycle rates. However, the more efficient design of ballscrew technology lends it to being backdriven when power is removed if precautions are not taken (e.g., electric brakes or counter loading).

Lead screws are capable of holding the load in position when power is removed, but are less efficient in operation. Kollmorgen’s guide system prevents rotation of the drive nut, thus eliminating any torque loading to machine linkage.

### Electric Cylinders Are Preferred When

- Positioning an externally guided and supported load
- Moving a load that pivots
- There is a high concentration of airborne contaminants (rodless actuators are inherently less well protected)
- Replacing a hydraulic or pneumatic cylinder with an electromechanical solution



### General Specifications

Series	N2		EC1	EC2		EC3		EC4	EC5
Std. Maximum Stroke Length inches (mm)	* 22.5 (571.5)		7.87 (200)	29.53 (750)		39.37 (1000)		59.06 (1500)	59.06 (1500)
Type of Screw	Lead	Ball	Ball	Lead	Ball	Lead	Ball	Ball	Ball
Lead	0.2 in, 0.5 in	0.2 in, 0.5 in	1.025 in	4 mm	16, 5 mm	4 mm	16, 10, 5 mm	25, 10 mm	32, 10 mm
Nom. Lead Screw Diameter	0.625 in	0.625 in	0.375 in	16 mm	16 mm	20 mm	20 mm	25 mm	32 mm
Backlash inches (mm)	0.016 (0.40)	0.015 (0.38)	0.015 (0.30)	0.016 (0.40)	0.010 (0.25)	0.016 (0.40)	0.010 (0.25)	0.12 (0.30)	0.12 (0.30)
Dimension Std.	English NFPA Std.		Metric ISO 6431 Std.	Metric ISO 6431 Std.		Metric ISO 6431 Std.		Metric ISO 6431 Std.	Metric ISO 6431 Std.
Bore size (mm)			0.875 in	50		63		80	100
Brushless Servomotor	AKM23, NEMA 23		AKM1x, NEMA 17	AKM23, NEMA 23		AKM23, NEMA 23 AKM42, NEMA 34 AKM52, NEMA 42 **		AKM42, NEMA 34 AKM52, NEMA 42 **	AKM42, NEMA 34 AKM52, NEMA 42 **
Max. Thrust lb. (N)	600 (2670)		150 (667)	810 (3600)		1620 (7200)		2700 (12,000)	5620 (25,000)
Max. Velocity in/sec (m/s)	12 (0.3)	30 (0.76)	13 (0.33)	9.2 (0.23)	50 (1.27)	8.0 (0.20)	50 (1.28)	52.5 (1.33)	52.5 (1.33)
Max. Rated Duty Cycle % (load, speed dependent)	50	100	100	50	100	50	100	100	100
Limit Switches	optional		optional	optional		optional		optional	optional
Std. Operating Temperature Range C (F)	32 to 140 (0 to 60)		-30 to +70 (-22 to 158)	-30 to +70 (-22 to 158)		-30 to +70 (-22 to 158)		-30 to +70 (-22 to 158)	-30 to +70 (-22 to 158)
Moisture/Contaminants	Humid, but Not Direct Contact		IP54 Std. IP65 Opt.	IP54 Std. IP65 Opt.		IP54 Std. IP65 Opt.		IP54 Std. IP65 Opt.	IP54 Std. IP65 Opt.

\* Requires dual rod-end bearing option for length over 12".

\*\* NEMA 42 mount, shaft does not follow a NEMA std.

# Electric Cylinders N2 / EC Series

## N2 MF1 Front Rectangular Flange Mount

Parallel

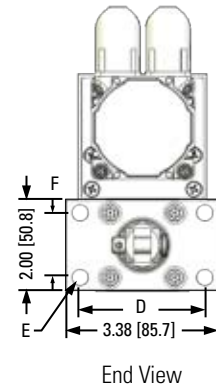
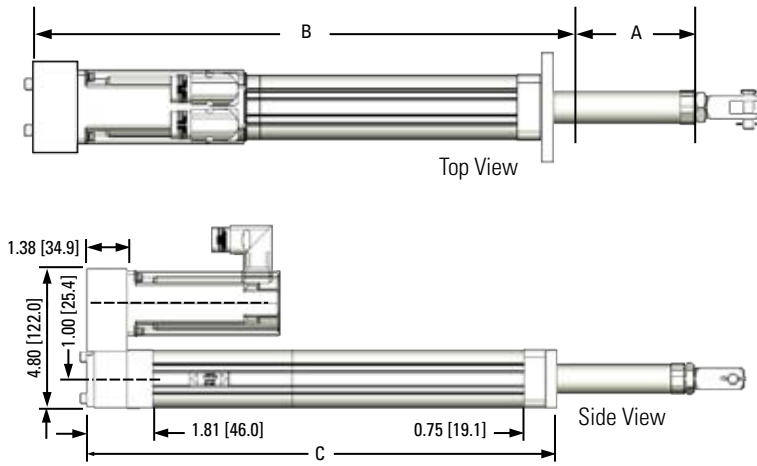

	English Option	Metric Option
D	2.75	72*
E	0.54	9*
F	1.43	36*

\* Meets ISO 40mm bore standard

## N2 Series Dimensions

A	Standard Stroke Lengths Available						
inch	2.0	4.0	6.0	8.0	12.0	18.0	24.0
mm	50.8	101.6	152.4	203.2	304.8	457.2	609.6

B	Retract Length	C	Mounting length
inch	5.37 + S	inch	5.06 + S
mm	136.4 + S	mm	128.5 + S

S = stroke

## EC MF1 Front Flange

Parallel

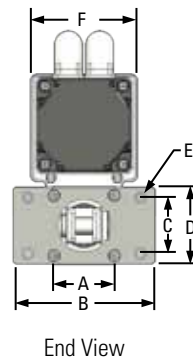
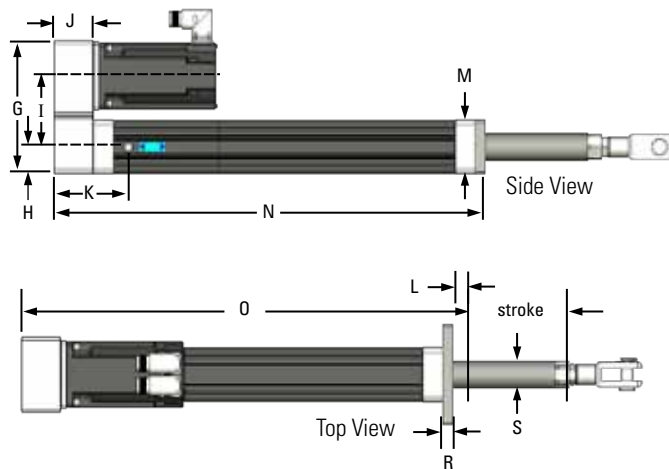

## Flange Dimensions

in accordance with ISO 6431 for:	
Type	Bore Size
EC1	30 mm
EC2	50 mm
EC3	63 mm
EC4	80 mm
EC5	100 mm

## EC Series Dimensions

	A	B	C	D	E	F	G	H
	mm (inch)	mm (inch)	mm (inch)	mm (inch)	mm (inch)	mm (inch)	mm (inch)	mm (inch)
EC1	60.0 (2.36)	74.0 (2.91)	28.0 (1.10)	40.0 (1.57)	6.60 (0.26)	48.0 (1.89)	82.6 (3.25)	19.0 (0.75)
EC2	90.0 (3.54)	114.3 (4.50)	45.0 (1.77)	63.5 (2.50)	9.0 (0.35)	79.8 (3.14)	144.0 (5.7)	28.4 (1.12)
EC3	100.0 (3.94)	127.0 (5.00)	50.0 (1.97)	69.1 (2.72)	9.0 (0.35)	95.5 (3.76)	169.7 (6.7)	34.8 (1.37)
EC4	127.0 (5.00)	152.4 (6.00)	69.9 (2.75)	96.3 (3.79)	13.5 (0.53)	127.0 (5.00)	221.0 (8.7)	46.1 (1.81)
EC5	150.0 (5.91)	186.9 (7.36)	75.0 (2.95)	114.3 (4.50)	13.97/14.35 (.555/.565)	127.0 (5.00)	221.0 (8.7)	46.1 (1.81)

	I	J	K	L	M	N Cyl Length	O Retract length
	mm (inch)	mm (inch)	mm (inch)	mm (inch)	mm (inch)	mm (inch)	mm (inch)
EC1	41.8 (1.65)	31.3 (1.23)	–	10.2 (0.40)	38.1 (1.50)	106.8 + S (4.2 + S)	117.0 + S (4.60 + S)
EC2	74.7 (2.94)	41.7 (1.64)	88.6 (3.49)	25.0 (0.98)	56.9 (2.24)	218.5 + S (8.6 + S)	243.4 + S (9.58 + S)
EC3	*87.6/89.7 (*3.45/3.53)	49.3 (1.94)	94.2 (3.71)	25.0 (0.98)	69.6 (2.74)	246.3 + S (9.7 + S)	271.1 + S (10.67 + S)
EC4	111.1 (4.37)	71.9 (2.83)	150.9 (5.94)	41.4 (1.63)	92.2 (3.63)	365.8 + S (14.4 + S)	406.9 + S (16.02 + S)
EC5	111.1 (4.37)	71.9 (2.83)	150.9 (5.94)	35.0 (1.38)	92.2 (3.63)	365.8 + S (14.4 + S)	406.9 + S (16.02 + S)

	P Breather port Hex		Q	R	S
	type	mm (inch)	mm (inch)	mm (inch)	mm (inch)
EC1	–	–	–	10.0 (0.39)	22.2 (0.88)
EC2	1/8 NPT	11.1 (0.44)	34.8 (1.37)	9.5 (0.37)	28.0 (1.10)
EC3	1/8 NPT	11.1 (0.44)	41.1 (1.62)	12.7 (0.50)	35.0 (1.38)
EC4	1/4 NPT	14.0 (0.55)	52.8 (2.08)	12.7 (0.50)	50.0 (1.97)
EC5	1/4 NPT	14.0 (0.55)	52.8 (2.08)	19.1 (0.75)	50.0 (1.97)

\* AKM23 / AKM24 dimension.

## 240 Vac Performance Data

Sys #	Electric Cylinder - AKM Servomotor	AKD Drive	Cont. Thrust @ Speed (lb @ in/sec)		Peak Thrust @ Speed (lb @ in/sec)		Max Thrust (lb)	Max System Speed (in/sec)	**Max Stroke for Max Speed (mm)
N2	1 N2-AKM23D-■■■■-10-5B *	AKD-X00306	190	12.0	600	11.5	600	12.0	18.0
	2 N2-AKM23D-■■■■-15-5B	AKD-X00306	287	8.0	600	8.0	600	8.0	18.0
	3 N2-AKM23D-■■■■-20-5B	AKD-X00306	382	6.0	600	6.0	600	6.0	18.0
	4 N2-AKM23D-■■■■-25-5B	AKD-X00306	370	4.8	600	4.8	600	4.8	18.0
	5 N2-AKM23D-■■■■-120-5B	AKD-X00306	600	1.0	600	1.0	600	1.0	18.0
	6 N2-AKM23D-■■■■-10-2B *	AKD-X00306	75	30.0	275	24.5	280	30.0	18.0
	7 N2-AKM23D-■■■■-15-2B	AKD-X00306	115	20.0	412	16.4	421	20.0	18.0
	8 N2-AKM23D-■■■■-20-2B	AKD-X00306	152	15.0	545	12.3	545	15.0	18.0
	9 N2-AKM23D-■■■■-25-2B	AKD-X00306	146	12.0	534	9.8	545	12.0	18.0
	10 N2-AKM23D-■■■■-120-2B	AKD-X00306	600	2.5	600	2.5	600	2.5	18.0
	11 N2-AKM23D-■■■■-10-5A-BZ *	AKD-X00306	86	12.0	305	9.8	312	12.0	18.0
	12 N2-AKM23D-■■■■-15-5A-BZ	AKD-X00306	128	8.0	458	6.5	467	8.0	18.0
	13 N2-AKM23D-■■■■-20-5A-BZ	AKD-X00306	169	6.0	600	4.9	600	6.0	18.0
	14 N2-AKM23D-■■■■-25-5A-BZ	AKD-X00306	165	4.8	593	3.9	600	4.8	18.0
	15 N2-AKM23D-■■■■-120-5A-BZ	AKD-X00306	600	1.0	600	1.0	600	1.0	18.0

Sys #	Electric Cylinder - AKM Servomotor	AKD Drive	Cont. Thrust @ Speed (lb @ in/sec)		Peak Thrust @ Speed (lb @ in/sec)		Max Thrust (lb)	Max System Speed (in/sec)	**Max Stroke for Max Speed (mm)
EC1	1 EC1-AKM11B-■■■■-10-03B *	AKD-X00306	50	13.0	75	13.0	75	13.0	200
	2 EC1-AKM11B-■■■■-20-03B	AKD-X00306	100	6.0	125	6.0	125	6.0	200
	3 EC1-AKM11B-■■■■-40-03B	AKD-X00306	150	3.0	150	3.0	150	3.0	200
	4 EC1-AKM13C-■■■■-10-03B*	AKD-X00306	75	11.5	75	13.0	75	13.0	200
	5 EC1-AKM13C-■■■■-20-03B	AKD-X00306	125	5.9	125	6.0	126	6.0	200

## 36 Vdc Stepper Performance Data

Sys #	Electric Cylinder - CT Step Motor	Cont. Thrust @ Speed (lb @ in/sec)		Max Thrust (lb)	Max System Speed (in/sec)	**Max Stroke for Max Speed (mm)
1	EC1-CTP12XLF10-10-03B	19.7	5.0	75	5.0	200
2	EC1-CTP12XLF10-20-03B	35.4	2.5	125	2.5	200
3	EC1-CTP12XLF10-40-03B	70.8	1.25	150	1.25	200

Note 1: Refer to page 62 for matching cables.

Note 2: For complete AKD, EC, and N2 Series model nomenclature, refer to pages 63, 68 and 69, respectively.

\* Inline type with 1-to-1 gear ratio (-10L) provide 10% additional thrust (not to exceed the Max thrust).

\*\* Based on critical speed of screw specification.

# Electric Cylinders N2 / EC Series

## 240 Vac Performance Data

Sys #	Electric Cylinder - AKM Servomotor	AKD Drive	Cont. Thrust @ Speed (lb @ in/sec)	Peak Thrust @ Speed (lb @ in/sec)	Max Thrust (lb)	Max System Speed (in/sec)	Max Stroke for Max Speed (mm)**	Cylinder Bore Size (EC)			
EC2	16	EC2-AKM23D-■■■■-10-04A *	AKD-X00306	108	9.2	387	7.7	396	9.2	200	50
	17	EC2-AKM23D-■■■■-15-04A	AKD-X00306	160	6.2	521	5.8	582	6.2	300	50
	18	EC2-AKM23D-■■■■-20-04A	AKD-X00306	216	4.6	455	4.6	622	4.6	450	50
	19	EC2-AKM23D-■■■■-50-04A	AKD-X00306	517	1.8	809	1.8	809	1.8	600	50
	20	EC2-AKM23D-■■■■-100-04A	AKD-X00306	809	0.9	809	0.9	809	0.9	750	50
	21	EC2-AKM23D-■■■■-10-16B *	AKD-X00306	60	50.5	218	30.9	223	50.5	200	50
	22	EC2-AKM23D-■■■■-15-16B	AKD-X00306	85	40.1	293	23.4	237	45.0	200	50
	23	EC2-AKM23D-■■■■-20-16B	AKD-X00306	116	29.5	245	24.5	350	31.0	300	50
	24	EC2-AKM23D-■■■■-50-16B	AKD-X00306	292	7.3	809	7.3	809	7.3	750	50
	25	EC2-AKM23D-■■■■-100-16B	AKD-X00306	581	3.7	809	3.7	809	3.7	750	50
	21	EC2-AKM23D-■■■■-10-05B *	AKD-X00306	186	16.3	697	9.7	712	16.3	200	50
	22	EC2-AKM23D-■■■■-15-05B	AKD-X00306	272	12.5	809	8.3	809	13.5	300	50
	23	EC2-AKM23D-■■■■-20-05B	AKD-X00306	370	9.2	782	7.6	809	10.0	300	50
	24	EC2-AKM23D-■■■■-50-05B	AKD-X00306	809	2.3	809	2.3	809	2.3	750	50
EC3	25	EC3-AKM23D-■■■■-15-16B	AKD-X00306	86	39.3	327	20.6	334	42.0	200	63
	26	EC3-AKM23D-■■■■-20-16B	AKD-X00306	119	28.6	448	14.0	459	30.0	300	63
	27	EC3-AKM23D-■■■■-50-16B	AKD-X00306	251	6.3	891	6.1	909	6.3	750	63
	28	EC3-AKM23D-■■■■-70-16B	AKD-X00306	349	4.5	1240	4.4	1260	4.5	1000	63
	29	EC3-AKM23D-■■■■-10-10B *	AKD-X00306	98	21.0	349	19.3	356	21.0	300	63
	30	EC3-AKM23D-■■■■-15-10B	AKD-X00306	141	21.0	523	12.9	534	21.0	300	63
	31	EC3-AKM23D-■■■■-20-10B	AKD-X00306	191	17.9	716	8.9	734	20.0	300	63
	32	EC3-AKM23D-■■■■-50-10B	AKD-X00306	404	3.8	1420	3.8	1450	3.8	1000	63
	33	EC3-AKM23D-■■■■-70-10B	AKD-X00306	561	2.8	1620	2.8	1620	2.8	1000	63
	34	EC3-AKM23D-■■■■-10-05B *	AKD-X00306	196	10.3	695	9.7	712	10.3	300	63
	35	EC3-AKM23D-■■■■-15-05B	AKD-X00306	285	10.3	1040	6.4	1070	10.3	300	63
	36	EC3-AKM23D-■■■■-20-05B	AKD-X00306	381	8.9	1430	4.4	1470	10.0	300	63
	37	EC3-AKM23D-■■■■-50-05B	AKD-X00306	800	2.0	1620	2.0	1620	2.0	750	63
	38	EC3-AKM23D-■■■■-70-05B	AKD-X00306	1120	1.4	1620	1.4	1620	1.4	1000	63
	38	EC3-AKM42G-■■■■-10-16B *	AKD-X00606	149	45.0	601	24.4	628	45.0	200	63
	39	EC3-AKM42G-■■■■-15-16B	AKD-X00606	223	30.0	510	24.0	736	30.0	300	63
	40	EC3-AKM42G-■■■■-50-16B	AKD-X00606	690	6.3	1620	6.3	1620	6.3	750	63
	41	EC3-AKM42G-■■■■-70-16B	AKD-X00606	965	4.5	1620	4.5	1620	4.5	1000	63
	42	EC3-AKM42G-■■■■-10-10B *	AKD-X00606	238	28.4	961	15.3	1010	21.0	300	63
	43	EC3-AKM42G-■■■■-15-10B	AKD-X00606	357	18.9	823	14.5	1200	21.0	300	63
44	EC3-AKM42G-■■■■-50-10B	AKD-X00606	1100	3.9	1620	3.9	1620	3.9	1000	63	
45	EC3-AKM42G-■■■■-70-10B	AKD-X00606	1530	2.8	1620	2.8	1620	2.8	1000	63	
46	EC3-AKM42G-■■■■-15-05B	AKD-X00606	710	10.3	1620	7.7	1620	10.3	300	63	

Note 1: Refer to page 62 for matching cables.

Note 2: For complete AKD and EC Series model nomenclature, refer to pages 63 and 68 respectively.

\* Inline type with 1-to-1 gear ratio (-10L) provide 10% additional thrust (not to exceed the Max thrust).

\*\* Based on critical speed of screw specification.



## 240 Vac Performance Data

Sys #	Electric Cylinder - AKM Servomotor	AKD Drive	Cont. Thrust @ Speed (lb @ in/sec)		Peak Thrust @ Speed (lb @ in/sec)		Max Thrust (lb)	Max System Speed (in/sec)	**Max Stroke for Max Speed (mm)	Cylinder Bore Size (EC)	
EC4	48	EC4-AKM42G-■■■■-10-25B *	AKD-X00606	108	52.5	395	36.1	402	52.5	300	80
	49	EC4-AKM42G-■■■■-15-25B	AKD-X00606	143	47.3	593	24.1	603	50.0	300	80
	50	EC4-AKM42G-■■■■-20-25B	AKD-X00606	190	35.4	791	18.1	804	36.0	450	80
	51	EC4-AKM42G-■■■■-50-25B	AKD-X00606	580	5.1	1940	5.1	1960	5.1	1500	80
	52	EC4-AKM42G-■■■■-100-25B	AKD-X00606	1130	2.6	2700	2.6	2700	2.6	1500	80
	53	EC4-AKM42G-■■■■-10-10B *	AKD-X00606	270	21.0	989	14.4	1005	15.3	450	80
	54	EC4-AKM42G-■■■■-15-10B	AKD-X00606	357	18.9	1480	9.6	1500	15.3	450	80
	55	EC4-AKM42G-■■■■-20-10B	AKD-X00606	476	14.2	1980	7.2	2010	14.5	450	80
	56	EC4-AKM42G-■■■■-50-10B	AKD-X00606	1440	2.1	2700	2.1	2700	2.1	1500	80
	57	EC4-AKM42G-■■■■-100-10B	AKD-X00606	2700	1.0	2700	1.0	2700	1.0	1500	80
	58	EC4-AKM52H-■■■■-10-25B *	AKD-X00606	256	36.3	458	30.7	668	36.3	300	80
	59	EC4-AKM52H-■■■■-15-25B	AKD-X00606	384	24.2	844	18.6	1200	24.2	600	80
	60	EC4-AKM52H-■■■■-20-25B	AKD-X00606	512	18.1	874	16.7	1160	18.1	750	80
	61	EC4-AKM52H-■■■■-50-25B	AKD-X00606	1360	5.1	2700	5.1	2700	5.1	1500	80
	62	EC4-AKM52H-■■■■-100-25B	AKD-X00606	2700	2.6	2700	2.6	2700	2.6	1500	80
	63	EC4-AKM52H-■■■■-10-10B *	AKD-X00606	640	14.5	1120	13.1	1670	14.5	450	80
	64	EC4-AKM52H-■■■■-15-10B	AKD-X00606	961	9.7	2090	8.0	2700	9.7	600	80
	65	EC4-AKM52H-■■■■-20-10B	AKD-X00606	1280	7.2	2190	6.7	2700	7.2	750	80
	66	EC4-AKM52H-■■■■-50-10B	AKD-X00606	2700	2.1	2700	2.1	2700	2.1	1500	80
	67	EC4-AKM52L-■■■■-10-25B *	AKD-X01206	240	52.5	422	52.5	700	52.5	300	80
	68	EC4-AKM52L-■■■■-15-25B	AKD-X01206	287	48.3	741	42.9	1090	48.3	300	80
	69	EC4-AKM52L-■■■■-20-25B	AKD-X01206	368	36.3	789	32.2	1040	36.3	450	80
	70	EC4-AKM52L-■■■■-50-25B	AKD-X01206	1370	5.1	2370	5.1	2370	5.1	1500	80
	71	EC4-AKM52L-■■■■-100-25B	AKD-X01206	2700	2.6	2700	2.6	2700	2.6	1500	80
	72	EC4-AKM52L-■■■■-10-10B *	AKD-X01206	650	15.3	1110	15.3	1500	15.3	300	80
73	EC4-AKM52L-■■■■-15-10B	AKD-X01206	860	15.3	1870	15.3	2700	15.3	300	80	
74	EC4-AKM52L-■■■■-20-10B	AKD-X01206	956	14.5	1970	13.0	2610	14.5	300	80	
75	EC4-AKM52L-■■■■-50-10B	AKD-X01206	2700	2.1	2700	2.1	2700	2.1	1500	80	
EC5	76	EC5-AKM42G-■■■■-10-32B *	AKD-X00606	88	52.5	309	46.3	314	52.5	450	100
	77	EC5-AKM42G-■■■■-15-32B	AKD-X00606	121	52.5	463	30.8	471	52.5	450	100
	78	EC5-AKM42G-■■■■-20-32B	AKD-X00606	149	45.4	618	23.1	628	45.4	450	100
	79	EC5-AKM42G-■■■■-50-32B	AKD-X00606	438	6.6	1530	6.6	1530	6.6	1500	100
	80	EC5-AKM42G-■■■■-100-32B	AKD-X00606	880	3.4	3000	3.4	3000	3.4	1500	100
	81	EC5-AKM42G-■■■■-10-10B *	AKD-X00606	270	15.3	989	14.4	1005	15.3	450	100
	82	EC5-AKM42G-■■■■-15-10B	AKD-X00606	400	15.3	1480	9.6	1510	15.3	450	100
	83	EC5-AKM42G-■■■■-20-10B	AKD-X00606	476	14.2	1980	7.2	2010	14.2	600	100
	84	EC5-AKM42G-■■■■-50-10B	AKD-X00606	438	6.6	1530	6.6	1530	6.6	1000	100
	85	EC5-AKM42G-■■■■-100-10B	AKD-X00606	880	3.4	3000	3.4	3000	3.4	1500	100
	86	EC5-AKM52H-■■■■-10-32B *	AKD-X00606	200	46.4	353	42.9	522	46.4	450	100
	87	EC5-AKM52H-■■■■-15-32B	AKD-X00606	300	30.9	935	2.3	935	30.9	750	100
	88	EC5-AKM52H-■■■■-20-32B	AKD-X00606	400	23.2	683	21.0	1010	23.2	750	100
	89	EC5-AKM52H-■■■■-50-32B	AKD-X00606	1080	6.6	3000	5.9	3045	6.6	1500	100
	90	EC5-AKM52H-■■■■-100-32B	AKD-X00606	2070	3.4	3630	3.4	3630	3.4	1500	100
	91	EC5-AKM52H-■■■■-10-10B *	AKD-X00606	641	14.5	1130	13.1	1670	14.5	450	100
	92	EC5-AKM52H-■■■■-15-10B	AKD-X00606	961	9.7	2080	8.0	3000	9.7	750	100
	93	EC5-AKM52H-■■■■-20-10B	AKD-X00606	1281	7.3	2180	6.7	3000	7.3	750	100
	94	EC5-AKM52H-■■■■-50-10B	AKD-X00606	3400	2.1	5620	2.1	5620	2.1	1500	100
	95	EC5-AKM52H-■■■■-100-10B	AKD-X00606	5620	1.0	5620	1.0	5620	1.0	1500	100
	96	EC5-AKM52L-■■■■-15-32B	AKD-X01206	261	52.5	580	52.5	853	52.5	450	100
	97	EC5-AKM52L-■■■■-20-32B	AKD-X01206	299	46.4	616	41.0	911	46.4	450	100
	98	EC5-AKM52L-■■■■-15-10B	AKD-X01206	860	15.3	1890	15.3	2730	15.3	450	100
	99	EC5-AKM52L-■■■■-20-10B	AKD-X01206	956	14.5	1970	12.8	2610	14.5	450	100

Note 1: Refer to page 62 for matching cables.

Note 2: For complete AKD and EC Series model nomenclature, refer to pages 63 and 68 respectively.

Ratings are based on the AKM servomotor and the matching AKD Drive. Specifications are based on 240 Vac, 3 phase voltage supply.

\* Inline type with 1-to-1 gear ratio (-10L) provide 10% additional thrust (not to exceed the Max thrust) \*\* Based on critical speed of screw specification.

# Rodless Actuators R-Series



The name “Rodless Actuator” comes from this technology’s close relationship to Electric Cylinders, sharing many of the same components. Rather than having a rod, Rodless Actuators incorporate a carriage supported by linear bearings. Where Electric Cylinders are designed to extend in and out of the work area delivering force or thrust, Rodless Actuators are designed to be load carrying mechanisms (up to 300 lb) incorporating ballscrews, leadscrews, or belt drive transmissions with optional integrated gearheads.

Rodless Actuators also share many of the fundamental design characteristics of Precision Positioning Tables. Precision Tables are designed to carry larger payloads and deliver superior repeatability and accuracy. Rodless Actuators offer longer travels and higher speeds at a lower price. Screw driven Rodless Actuators are also thrust-producing devices that are best for axial force applications where the space is limited and a payload must also be supported or carried. As individual components, Rodless Actuators are not well suited for moment loading; however, they can be effectively combined into complete Cartesian Systems for some multi-axis applications. For higher speed, lower thrust applications, Rodless Actuators can be repeatability-driven with a timing belt instead of a screw.

Kollmorgen has combined the broad product offering of the R-Series Rodless Actuators with the industry leading AKM servomotors and AKD drives. The R-Series of Rodless Actuators offer a wide range of available thrusts in standard units with three basic frame sizes (R2A, R3, R4).

Rodless Actuators offer longer travels (up to 108") and higher speeds (belt drives up to a maximum speed of 120 in/sec). Integrated geared options provide the ability to increase thrust capacity for lower speed applications leveraging the speed capacity of servo systems.

Multiple servomotor options are available for the product line, ranging from NEMA 23 size to NEMA 42 size servos. The combination with the AKM Servomotor enables the use of various feedback devices including sine-encoder and the low-cost but high-performance Smart Feedback Device (SFD) when used with the AKD drive.

The AKM Servomotor comes mounted on the Rodless Actuators as specified by the Rodless Actuator part number. This eliminates time to match the motor to the Electric Cylinder and eliminates potential mechanical incompatibility.

**The operation of Rodless Actuators is similar to the Electric Cylinders described earlier.** However, instead of an extending rod, a rodless unit features a moving carriage supported by linear bearings within an extruded aluminum chassis. This gives the rodless actuator the ability to guide and support a load, as well as position it.

Kollmorgen Rodless Actuators are designed for outstanding overall performance, value, flexibility and reliability in industrial applications.

### Rodless Actuators Are Preferred When

- A low cost system is needed to both position and guide a load
- It is desired to eliminate external guides and ways
- The shortest overall work envelope (extended length equals retracted length) is required
- Multiple units will be combined into Cartesian Systems
- There is a need for a compact cross-sectional linear positioning system

### Common Features

- Ready to mount motor/actuator systems in choice of lengths, with one week delivery

### Typical Construction

(R4 belt-driven cutaway shown)

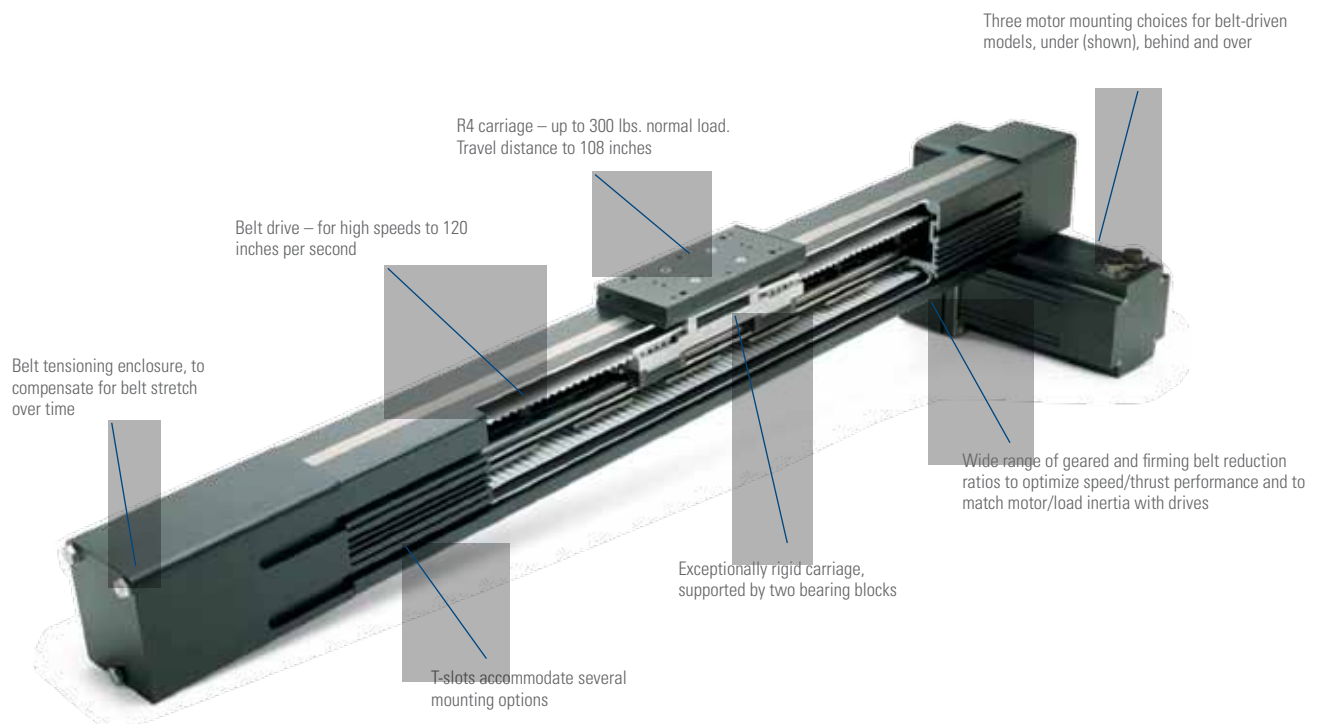

# Rodless Actuators R-Series

## R3 Screw Drive

R3 screw drive with AKM42, parallel below motor orientation and flange mounting shown.

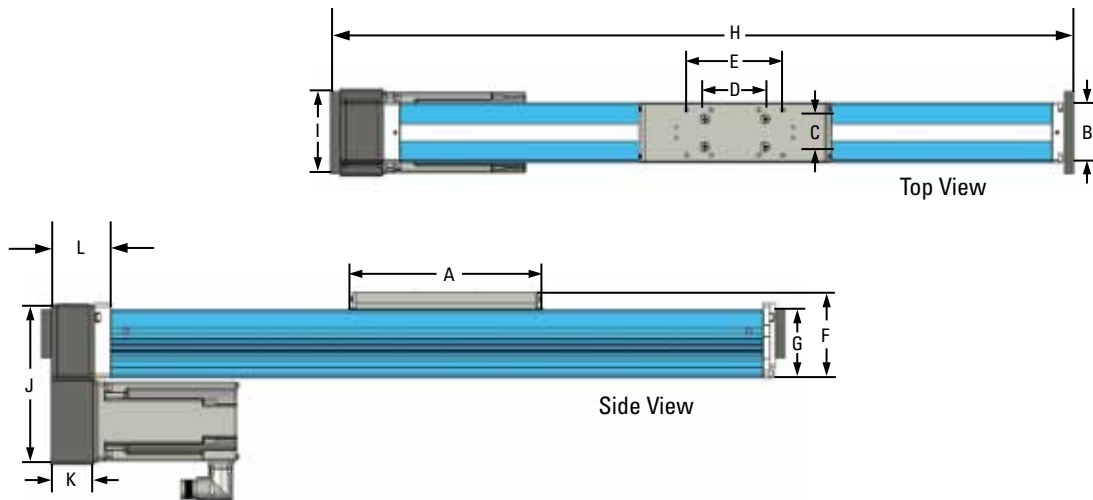

## R3 Belt Drive

R3 belt drive with AKM42, behind left motor orientation and angle bracket feet shown.

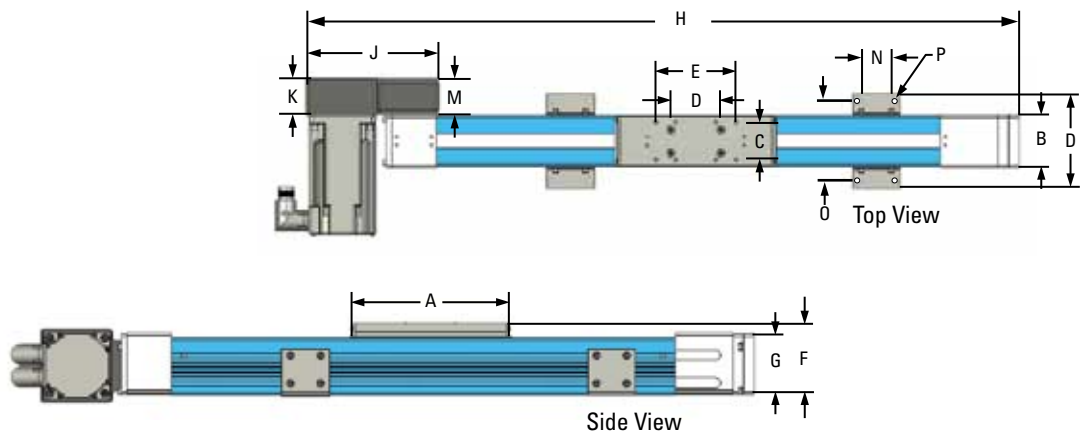

## Carriage Mounting Features

	Metric Version (mm)	English Version (inch)
RA2	8 x M5 x 0.8 x 8.0 deep	8 x 10-32 UNF x 0.31 deep
R3	8 x M5 x 0.8 x 9.6 deep	8 x 10-32 UNF x 0.38 deep
R4	4 x M6 x 1 x 12 deep	4 x 1/4-20 x 0.50 deep

## Dimension Data

	A	B	C	D	E
	mm (in)	mm (in)	mm (in)	mm (in)	mm (in)
RA2	210 (8.25)	50.8 (2.00)	31.8 (1.25)	50.8 (2.00)	101.6 (4.00)
R3	197 (7.76)	63.5 (2.50)	47.6 (1.88)	50.8 (2.00)	101.6 (4.00)
R4	197 (7.76)	92.2 (3.63)	63.5 (2.50)	NA	127.0 (5.00)

	F	G	H (Screw)	H (Belt)
	mm (in)	mm (in)	mm (in)	mm (in)
RA2	71.9 (2.83)	50.8 (2.00)	"S" + 345.3 (13.59)	"S" + 378.3 (14.89)
R3	88.8 (3.50)	71.5 (2.82)	"S" + 326.4 (12.85)	"S" + 522.0 (20.55)
R4	71.9 (2.83)	108.0 (4.25)	"S" + 411.8 (16.21)	"S" + 578.6 (22.78)

S = stroke

	I	J	K	L
	mm (in)	mm (in)	mm (in)	mm (in)
RA2	72.1 (2.84)	123.2 (4.85)	43.0 (1.69)	90.7 (3.57)
R3	91.4 (3.60)	168.9 (6.65)	45.5 (1.79)	88.1 (3.47)
R4	127.0 (5.00)	220.7 (8.69)	71.9 (2.83)	147.8 (5.82)

	M	N	O	P
	mm (in)	mm (in)	mm (in)	mm (in)
RA2	50.1 (1.97)	NA	88.8 (3.50)	8.7 (0.34) thru
R3	45.5 (1.79)	47.6 (1.88)	101.6 (4.00)	5.5 (0.22) thru
R4	71.9 (2.83)	63.5 (2.50)	127.0 (5.00)	7.0 (0.28) thru

# Rodless Actuators R-Series

## General Specifications

Series	R2A			R3			R4	
Std Max Stroke Length (in)	72			108			108	
Cross Section (in)	2 x 2			2.5 x 2.8			3.6 x 4.25	
Guide Type	Roller Guides			Profile Rail			Profile Rail	
Drive Type	Ballscrew	Lead Screw	Belt	Ballscrew	Lead Screw	Belt	Ballscrew	Belt
Screw Leads (in/rev)	0.5, 0.2	0.2, 0.125	n/a	0.5, 0.2	0.2, 0.125	n/a	1, 0.25	n/a
Nominal Screw Diameter (in)	0.625	0.625	n/a	0.625	0.625	n/a	1	n/a
Brushless Servomotor	AKM23, NEMA 23			AKM23, NEMA 23, AKM42, NEMA 34			n/a	
Max Thrust (lb)	100		72	300		200	700	300
Max Velocity (in/sec)	30		80	30		120	40	120
Max Carriage Load								
Normal (lb)	5			100			300	
Roll Moment (lb-in)	50			300			600	
Pitch Moment (lb-in)	100			500			1000	
Repeatability (in)	+/-0.001		+/-0.010	+/-0.001		+/-0.010	+/-0.001	+/-0.010
Max Duty Cycle (speed, load dependent)	100%	60%	100%	100%	60%	100%	100%	100%
Limit Sensors	Optional							
Std Operating Temperature Range	-20 deg F to 140 deg F (-28 deg C to 60 deg C)							
Moisture/Contamination	IP 44 rated: Splash-proof, protected against ingress of solid particles greater than 0.040 [1 mm] diameter.*							

## 240 Vac Performance Data

Sys #	Rodless Actuator-Servomotor	AKD Drive	Cont. Thrust @ Speed (lb @ in/sec)		Peak Thrust @ Speed (lb @ in/sec)		Max Thrust (lb)	Max System Speed (in/sec)	Max Stroke for Max Speed (in)	
R2A	1	R2A-AKM23D-10-2B*	AKD-X00306	70	30	100	30	100	30	18
	2	R2A-AKM23D-15-2B	AKD-X00306	100	20	100	20	100	20	24
	3	R2A-AKM23D-20-2B	AKD-X00306	100	15	100	15	100	15	30
	4	R2A-AKM23D-10-5B	AKD-X00306	100	12	100	12	100	12	18
	5	R2A-AKM23D-15-5B	AKD-X00306	100	8.0	100	8.0	100	8.0	24
	6	R2A-AKM23D-20-5B	AKD-X00306	100	6.0	100	6.0	100	6.0	30
	7	R2A-AKM23D-10-5A*	AKD-X00306	78	12	100	12	100	12	12
	8	R2A-AKM23D-15-5A	AKD-X00306	100	8.0	100	8.0	100	8.0	18
	9	R2A-AKM23D-20-5A	AKD-X00306	100	6.0	100	6.0	100	6.0	24
	10	R2A-AKM23D-10-T*	AKD-X00306	7.2	80	40	80	40	80	72
	11	R2A-AKM23D-15-T	AKD-X00306	14	80	64	80	64	80	72
	12	R2A-AKM23D-20-T	AKD-X00306	19	80	78	80	87	80	72
R3	13	R3-AKM23D-10-2B*	AKD-X00306	71	30	269	25	270	25	18
	14	R3-AKM23D-15-2B	AKD-X00306	108	20	300	20	300	20	24
	15	R3-AKM23D-20-2B	AKD-X00306	148	15	300	15	300	15	30
	16	R3-AKM23D-50-2B	AKD-X00306	300	6.0	300	6.0	300	6.0	48
	17	R3-AKM23D-10-5B*	AKD-X00306	186	12	300	12	300	12.0	18
	18	R3-AKM23D-15-5B	AKD-X00306	270	8.0	300	8.0	300	8.0	24
	19	R3-AKM23D-20-5B	AKD-X00306	300	6.0	300	6.0	300	6.0	30
	20	R3-AKM23D-50-5B	AKD-X00306	300	2.4	300	2.4	300	2.4	48
	21	R3-AKM23D-10-5A*	AKD-X00306	75	12	250	12	300	12	12
	22	R3-AKM23D-15-5A	AKD-X00306	120	8.0	300	8.0	300	8.0	18
	23	R3-AKM23D-20-5A	AKD-X00306	160	6.0	300	6.0	300	6.0	24
	24	R3-AKM23D-50-5A	AKD-X00306	300	2.4	300	2.4	300	2.4	42
	25	R3-AKM23D-10-8A*	AKD-X00306	128	7.5	300	7.5	300	7.5	18
	26	R3-AKM23D-15-8A	AKD-X00306	200	5.0	300	5.0	300	5.0	30
	27	R3-AKM23D-20-8A*	AKD-X00306	260	3.8	300	3.8	300	3.8	30
	28	R3-AKM23D-50-8A	AKD-X00306	300	1.5	300	1.5	300	1.5	48
	29	R3-AKM23D-10-T*	AKD-X00306	1.0	110	18	110	18	110	108

Note 1: Refer to page 62 for matching cables. Note 2: For complete AKD and R-Series model nomenclature, refer to pages 63 and 70 respectively.

\* Inline type with 1-to-1 gear ratio (-10L) provide 10% additional thrust (not to exceed the Max thrust).

## 240 Vac Performance Data

Sys #	Rodless Actuators-Servomotor	AKD Drive	Cont. Thrust @ Speed (lb @ in/sec)		Peak Thrust @ Speed (lb @ in/sec)		Max Thrust (lb)	Max System Speed (in/sec)	Max Stroke for Max Speed (in)	
R3	30	R3-AKM23D-■■■■-15-T	AKD-X00306	4.4	110	29	110	29	110	108
	31	R3-AKM23D-■■■■-20-T	AKD-X00306	8.0	110	40	110	41	110	108
	32	R3-AKM23D-■■■■-50-T	AKD-X00306	20	72	90	72	92	72	108
	33	R3-AKM23D-■■■■-70-T	AKD-X00306	30	51	128	51	131	51	108
	34	R3-AKM42G-■■■■-10-2B	AKD-X00606	200	30	300	30	300	30	18
	35	R3-AKM42G-■■■■-15-2B	AKD-X00606	300	20	300	20	300	20	24
	36	R3-AKM42G-■■■■-20-2B	AKD-X00606	300	15	300	15	300	15	30
	37	R3-AKM42G-■■■■-50-2B	AKD-X00606	300	6.0	300	6.0	300	6.0	48
	38	R3-AKM42G-■■■■-10-5B	AKD-X00606	300	12	300	12	300	12	18
	39	R3-AKM42G-■■■■-15-5B	AKD-X00606	300	8.0	300	8.0	300	8.0	24
	40	R3-AKM42G-■■■■-20-5B	AKD-X00606	300	6.0	300	6.0	300	6.0	30
	41	R3-AKM42G-■■■■-50-5B	AKD-X00606	300	2.4	300	2.4	300	2.4	48
	42	R3-AKM42G-■■■■-10-5A	AKD-X00606	221	12	300	12	300	12	12
	43	R3-AKM42G-■■■■-15-5A	AKD-X00606	300	8.0	300	8.0	300	8.0	18
	44	R3-AKM42G-■■■■-20-5A	AKD-X00606	300	6.0	300	6.0	300	6.0	24
	45	R3-AKM42G-■■■■-50-5A	AKD-X00606	300	2.4	300	2.4	300	2.4	42
	46	R3-AKM42G-■■■■-10-8A	AKD-X00606	300	7.5	300	7.5	300	7.5	18
	47	R3-AKM42G-■■■■-15-8A	AKD-X00606	300	5.0	300	5.0	300	5.0	24
	48	R3-AKM42G-■■■■-20-8A	AKD-X00606	300	3.8	300	3.8	300	3.8	30
	49	R3-AKM42G-■■■■-50-8A	AKD-X00606	300	1.5	300	1.5	300	1.5	60
	50	R3-AKM42G-■■■■-10-T	AKD-X00606	15	110	59	110	60	110	108
	51	R3-AKM42G-■■■■-15-T	AKD-X00606	25	110	92	110	93	110	108
	52	R3-AKM42G-■■■■-20-T	AKD-X00606	32	110	124	110	126	110	108
	53	R3-AKM42G-■■■■-50-T	AKD-X00606	66	72	200	72	200	72	108
54	R3-AKM42G-■■■■-70-T	AKD-X00606	94	51	200	51	200	51	108	
R4	55	R4-AKM42G-■■■■-10-1B	AKD-X00606	103	40	384	37	390	40	36
	56	R4-AKM42G-■■■■-15-1B	AKD-X00606	160	27	578	25	588	27	48
	57	R4-AKM42G-■■■■-20-1B	AKD-X00606	210	20	700	20	700	20	60
	58	R4-AKM42G-■■■■-50-1B	AKD-X00606	460	7.8	700	7.8	700	7.8	96
	59	R4-AKM42G-■■■■-100-1B	AKD-X00606	700	4.0	700	4.0	700	4.0	108
	60	R4-AKM42G-■■■■-10-4B	AKD-X00606	440	10.0	700	10.0	700	10	36
	61	R4-AKM42G-■■■■-15-4B	AKD-X00606	630	6.7	700	6.7	700	6.7	48
	62	R4-AKM42G-■■■■-20-4B	AKD-X00606	700	6.7	700	6.7	700	6.7	48
	63	R4-AKM42G-■■■■-50-4B	AKD-X00606	700	6.7	700	6.7	700	6.7	48
	64	R4-AKM42G-■■■■-10-T	AKD-X00606	11	110	47	110	47	110	108
	65	R4-AKM42G-■■■■-15-T	AKD-X00606	18	110	73	110	74	110	108
	66	R4-AKM42G-■■■■-20-T	AKD-X00606	25	110	98	110	100	110	108
	67	R4-AKM42G-■■■■-30-T	AKD-X00606	38	100	150	92	153	100	108
	68	R4-AKM42G-■■■■-50-T	AKD-X00606	56	59	215	54	219	59	108
	69	R4-AKM42G-■■■■-100-T	AKD-X00606	118	30	300	30	300	30	108
	70	R4-AKM52H-■■■■-10-1B	AKD-X00606	246	37	700	37	700	37	36
	71	R4-AKM52H-■■■■-15-1B	AKD-X00606	372	25	700	25	700	25	48
	72	R4-AKM52H-■■■■-20-1B	AKD-X00606	498	18	700	18	700	18	60
	73	R4-AKM52H-■■■■-50-1B	AKD-X00606	700	7.8	700	7.8	700	7.8	96
	74	R4-AKM52H-■■■■-10-4B	AKD-X00606	700	9.2	700	9.2	700	9.2	36
	75	R4-AKM52H-■■■■-15-4B	AKD-X00606	700	6.7	700	6.7	700	6.7	48
	76	R4-AKM52H-■■■■-20-4B	AKD-X00606	700	4.9	700	4.9	700	4.9	60
	77	R4-AKM52H-■■■■-50-4B	AKD-X00606	700	1.9	700	1.9	700	1.9	96
	78	R4-AKM52H-■■■■-10-T	AKD-X00606	30	110	97	110	99	110	108
	79	R4-AKM52H-■■■■-15-T	AKD-X00606	51	110	149	110	152	110	108
	80	R4-AKM52H-■■■■-20-T	AKD-X00606	65	110	201	90	204	110	108
	81	R4-AKM52H-■■■■-30-T	AKD-X00606	95	92	300	60	300	95	108
	82	R4-AKM52H-■■■■-50-T	AKD-X00606	137	54	300	44	300	54	108
	83	R4-AKM52H-■■■■-100-T	AKD-X00606	275	27	300	27	300	27	108

Note 1: Refer to page 62 for matching cables. Note 2: For complete AKD and R-Series model nomenclature, refer to pages 63 and 70 respectively.



# Micron™ TRUE Planetary™ Gearheads

Helical gears are known for their quiet and smooth operation along with their ability to transmit higher loads than spur gears. Both of these features of helical gearing result from the improved contact ratio (effective teeth in mesh) over spur gears.

A high torque, whisper quiet helical gearhead has been designed by combining the positive attributes of gear crowning and helical gearing with the planetary construction to create the smoothest operating gearhead on the market.

- Broadest product range of gearheads in the industry
- Innovative gear technology offers size and performance advantages
- RediMount™ system provides error-free and reliable installations

## Helical Crowned TRUE Planetary™ Gearing

### Features

- High torque capacity
- Low backlash
- Smooth operation
- Greater load sharing
- Whisper quiet

### Spur vs. Helical Gearing

Typical contact ratio is 1.5 for spur gearing. Contact ratio for equivalent helical gear is 3.3 – more than double the contact ratio.

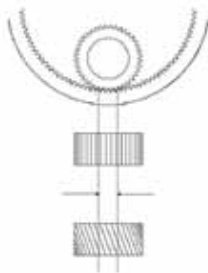

### Crowned vs. Non-Crowned

Crowning optimizes the gear mesh alignment within a gear train to increase the torque capacity and reduce noise. It also enhances load distribution on the tooth flank to reduce high stress regions.

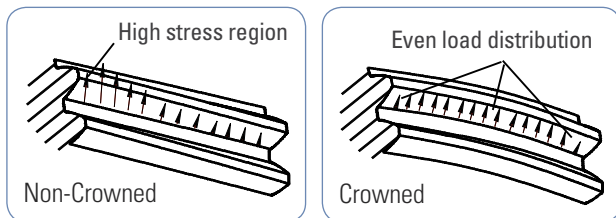

## PowerTRUE™ Right Angle Gearheads

- Lower backlash from single axis mesh adjustment
- A compact design using Face Gear technology
- Whisper quiet operation due to high contact ratio
- Mesh ratios from 1:1 to 5:1
- Extremely efficient (98%)

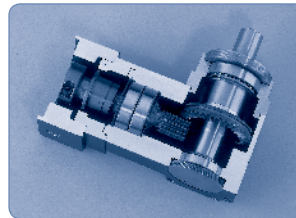

PowerTRUE™ Gear Technology

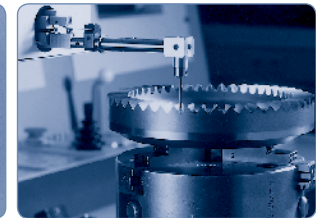

Computerized mapping of gear tooth profile

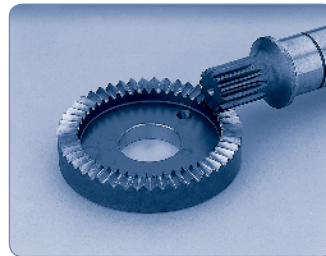

All Micron™ Right Angle Gearheads use the PowerTRUE Technology which increases the mesh ratio to 5:1 compared to a maximum of 3:1 typical in bevel gears.

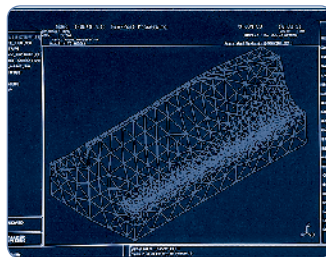

Multiple teeth in the Face Gear simultaneously mesh with a standard involute pinion. The continuous tooth engagement yields a high contact ratio between the gear and the pinion, increasing torque and efficiency.

NEMA TRUE™		True Planetary gearhead, flange mount design with anodized aluminum housing employing RediMount™ system.						
Inline	Frame Size		Max T Peak (lb-in)		All Sizes	Gear Ratios Available	Efficiency	Backlash (arc-min)
	English	Metric	1 Stage	2 Stage				
Size 17	NEMA 17	42 mm	170	170	1 Stage	3, 4, 5, 7, 10	93%	13 (8)*
Size 23 / 60	NEMA 23	60 mm	250	275				
Size 34 / 90	NEMA 34	90 mm	700	850	2 Stage	15, 20, 25, 30, 40, 50, 70, 100	88%	15 (9)*
Size 42 / 115	NEMA 42	115 mm	1000	1600				



NEMA TRUE™		True Planetary gearhead, flange mount design with anodized aluminum housing employing RediMount™ system.							
Right Angle	Frame Size		Max T Peak (lb-in)			All Sizes	Gear Ratios Available	Efficiency	Backlash (arc-min)
	English	Metric	1 Stage	2 Stage	3 Stage				
Size 23 / 60	NEMA 23	60 mm	360	366	366	1 Stage	1, 2, 3, 4, 5P	98%	13
Size 34 / 90	NEMA 34	90 mm	1110	1110	1110	2 Stage	5T, 6, 9, 10, 12, 15, 20, 25, 30, 40, 50	93%	15
Size 42 / 115	NEMA 42	115 mm	2250	2250	2250	3 Stage	60, 75, 90, 100, 120, 125, 150, 200, 250, 300, 400, 500	88%	15



XTRUE™		The XTRUE Series is a new precision gearhead employing RediMount™ system that compliments our TRUE Planetary gearhead line – already the largest selection of planetary gearheads in the world.						
Inline	Frame Size Metric	Max T Peak (lb-in)		All Sizes	Gear Ratios Available	Efficiency	Backlash (arc-min)	
		1 Stage	2 Stage					
XT040	40 mm	162	299	1 Stage	3, 4, 5, 7, 10	93%	13	
XT060	60 mm	483	483					
XT080	80 mm	1460	1550					
XT120	120 mm	2640	2640	2 Stage	15, 20, 25, 30, 40, 50, 70, 100	88%	15	
XT160	160 mm	7750	7750					



EverTRUE™		EverTRUE, employing RediMount™ system, is specifically designed for 24/7 continuous running applications providing 3 times (30,000 hours) service life.						
Inline	Frame Size Metric	Max T Peak (lb-in)		All Sizes	Gear Ratios Available	Efficiency	Backlash (arc-min)	
		1 Stage	2 Stage					
ET010	101 mm	4090	4790	1 Stage	4, 5, 7, 10	95%	4	
ET014	141 mm	9430	11,250					
ET018	182 mm	21,600	26,280	2 Stage	16, 20, 25, 28, 35, 40, 50, 70, 100	90%	5	





\* High Precision, low backlash versions available, low backlash value in parenthesis (Not available in size 17).  
 Note 1: Torque capacity is maximum of frame size stage design, not all ratios have the same rated torque capacity.  
 Note 2: Torque capacity is the maximum allowable momentary torque for emergency stopping or heavy shock loading.  
 Note 3: Ratio 5P is designed using the compact PowerTrue face gearing technology.  
 Note 4: Ratio 5T is designed using a True Planetary gear stage for increased torque capacity.  
 Note 5: For complete Gearhead model nomenclature, refer to page 71.





# Micron™ TRUE Planetary™ Gearheads

A K D S E R V O S Y S T E M S  
T R U E P L A N E T A R Y G E A R H E A D S

DuraTRUE™	True Planetary gearhead, flange mount design with anodized aluminum housing employing RediMount™ system.							
	Inline	Frame Size Metric	Max T Peak (lb-in)		All Sizes	Gear Ratios Available	Efficiency	Backlash (arc-min)
			1 Stage	2 Stage				
	DT60	60 mm	460	460	1 Stage	3, 4, 5, 7, 10	93%	9
	DT90	90 mm	1480	1480				
	DT115	115 mm	2510	2510	2 Stage	15, 20, 25, 30, 40, 50, 70, 100	88%	8
	DT142	142 mm	7380	7380				

DuraTRUE™	True Planetary right angle gearhead, flange mount design with anodized aluminum housing employing RediMount™ system.							
	Right Angle	Frame Size Metric	Max T Peak (lb-in)		All Sizes	Gear Ratios Available	Efficiency	Backlash (arc-min)
			1 Stage	2 Stage				
	DT60	60 mm	460	460	1 Stage	5, 6, 9, 10, 12, 15, 20, 25, 30, 40, 50	93%	9
	DT90	90 mm	1480	1480				
	DT115	115 mm	2510	2510	2 Stage	60, 75, 90, 100, 120, 125, 150, 200, 250, 300, 400, 500	88%	8
	DT142	142 mm	7380	7380				

Slimline	Slimline right angle gearhead, flange mount design with anodized aluminum housing employing RediMount™ system. Face Gear technology for compact right angle construction. Dual shaft output version also available.								
	Right Angle	Frame Size Metric	Max T Peak (lb-in)			All Sizes	Gear Ratios Available	Efficiency	Backlash (arc-min)
			1 Stage	2 Stage	3 Stage				
	DT60S	60 mm	460	400	400	1 Stage	1, 2, 3, 4, 5P	98%	8
	DT90S	90 mm	1240	1240	1240	2 Stage	5T, 6, 9, 10, 12, 15, 20, 25, 30, 40, 50	93%	9
	DT115S	115 mm	2260	2500	2500	3 Stage	60, 75, 90, 100, 120, 125, 150, 200, 250, 300, 400, 500	88%	9
	DT142S	142 mm	5500	6920	7450				

Hollow Shaft	Hollow shaft right angle gearhead, flange mount design with anodized aluminum housing employing RediMount™ system. Large diameter/ bolt circle for direct mechanical interface. Face Gear technology for compact right angle construction.								
	Right Angle	Frame Size Metric	Max T Peak (lb-in)			All Sizes	Gear Ratios Available	Efficiency	Backlash (arc-min)
			1 Stage	2 Stage	3 Stage				
	DT90H	90 mm	1240	1240	1240	1 Stage	1, 2, 3, 4, 5P	98%	8
	DT115H	115 mm	2500	2500	2500	2 Stage	5T, 6, 9, 10, 12, 15, 20, 25, 30, 40, 50	93%	9
	DT142H	142 mm	7660	7660	7660	3 Stage	60, 75, 90, 100, 120, 125, 150, 200, 250, 300, 400, 500	88%	9

Note 1: Torque Capacity is maximum of frame size stage design, not all ratios have the same rated torque capacity.  
 Note 2: Torque Capacity is the maximum allowable momentary torque for emergency stopping or heavy shock loading.  
 Note 3: Ratio 5P is designed using the compact PowerTrue face gearing technology.  
 Note 4: Ratio 5T is designed using a True Planetary gear stage for increased torque capacity.  
 Note 5: For complete Gearhead model nomenclature, refer to page 71.



ValueTRUE™	Helical True Planetary gearhead, flange mount design with stainless steel housing employing RediMount™ system.							
	Inline	Frame Size Metric	Max T Peak (lb-in)		All Sizes	Gear Ratios Available	Efficiency	Backlash (arc-min)
			1 Stage	2 Stage				
	VT006	61 mm	800	910	1 Stage	4, 5, 7, 10	95%	4
	VT075	75 mm	1420	1630				
	VT090	90 mm	1420	1630				
	VT010	101 mm	4090	4790				
	VT115	115 mm	4090	4790	2 Stage	16, 20, 25, 28, 35, 40, 50, 70, 100	93%	5
	VT014	141 mm	9430	11,250				
	VT018	182 mm	21,600	26,280				
	VT022	220 mm	36,980	44,000				

ValueTRUE™	Helical True Planetary gearhead, flange mount design with stainless steel housing employing RediMount™ system.							
	Right Angle	Frame Size Metric	Max T Peak (lb-in)		All Sizes*	Gear Ratios Available	Efficiency	Backlash (arc-min)
			2 Stage					
	VTR006	61 mm	870		2 Stage	4, 5, 8, 10, 12, 14, 15, 16, 20, 25, 28, 30, 35, 40, 50	93%	5
	VTR075	75 mm	1570					
	VTR090	90 mm	1570					
	VTR010	101 mm	4580					
	VTR115	115 mm	4580					
	VTR014	141 mm	10,670					
	VTR018	182 mm	24,780					

\* 4 and 5:1 ratios not available with VTR006-VTR090.

UltraTRUE™	Helical True Planetary inline gearhead, flange mount design with anodized aluminum housing employing RediMount™ system. Stainless steel housing, gear-path hobbled into stainless steel housing.							
	Inline	Frame Size Metric	Max T Peak (lb-in)		All Sizes	Gear Ratios Available	Efficiency	Backlash (arc-min)
			1 Stage	2 Stage				
	UT006	61 mm	890	1010	1 Stage	4, 5, 7, 10	95%	4
	UT075	75 mm	1580	1810				
	UT090	90 mm	1580	1810				
	UT010	101 mm	4540	5330				
	UT115	115 mm	4540	5330	2 Stage	16, 20, 25, 28, 35, 40, 50, 70, 100	90%	5
	UT014	141 mm	10,480	12,500				
	UT018	182 mm	24,101	29,200				
	UT022	220 mm	41,090	48,890				

UltraTRUE™	Helical True Planetary right angle gearhead, flange mount design with anodized aluminum housing employing RediMount™ system. Stainless steel housing, gear-path hobbled into stainless steel housing.							
	Right Angle	Frame Size Metric	Max T Peak (lb-in)		All Sizes	Gear Ratios Available	Efficiency	Backlash (arc-min)
			1 Stage	2 Stage				
	UTR006	61 mm	450	970	1 Stage	1, 2, 3, 4, 5	98%	4
	UTR075	75 mm	1410	1740				
	UTR090	90 mm	1410	1740				
	UTR010	101 mm	2850	5080				
	UTR115	115 mm	2850	5080	2 Stage	8, 10, 12, 14, 15, 16, 20, 25, 28, 30, 35, 40, 50	93%	5
	UTR014	141 mm	6270	11,860				
	UTR018	182 mm	16,910	27,530				

Note 1: Torque capacity is maximum of frame size stage design, not all ratios have the same rated torque capacity.  
 Note 2: Torque capacity is the maximum allowable momentary torque for emergency stopping or heavy shock loading.  
 Note 3: Ratio 5P is designed using the compact PowerTrue face gearing technology.  
 Note 4: Ratio 5T is designed using a True Planetary gear stage for increased torque capacity.  
 Note 5: For complete Gearhead model nomenclature, refer to page 71.



# Stepper Products

**Our Stepper Motors, Drives and Controllers, which accommodate a wide range of power requirements, provide a high-performance, yet very cost-effective solution when you need precise motion control.** In addition, our Stepper Motors are the highest torque-density motors in the industry, simple to control and don't require complicated, expensive feedback devices. They're available in a wide range of lengths, windings and shafts.

We also offer hybrid stepper motors that deliver more power in a smaller package. These rugged NEMA 34 and 42 (90 and 110 mm) frame motors provide among the highest torques per frame size in the industry.

Due to their ease of use, simplified control needs and freedom from expensive feedback requirements, our step motors are excellent alternatives to pneumatic, hydraulic and servomotor systems.

# P7000 Stepper Drive-Controller

P7000 Stepper Drives offer a unique level of system functionality, smoothness, high-speed performance and innovation unmatched in the industry.

The compact P7000 is designed to power Kollmorgen step motors ranging from NEMA size 17 up to NEMA size 34. Two power configurations are available for operation directly from AC power, or from a DC power supply.

There are two levels of control offered. The basic drive accepts step and direction inputs. P7000 drives are also available with an integrated position controller (-PN option). The drives are configured by either on-board dip switches, or with the P7000 tools software.



## Advanced P7000 Features Make it the Best Choice to Meet Your Application Requirements.

### Multisteping™

Also known as auto-smoothing. The P7000 drive accepts full step pulse commands from the indexer and inserts fine micro-steps to smooth coarse low speed motion. This allows you to significantly upgrade machine performance without having to redesign machine control architecture.

### Auto-Tuning

Advanced current auto-tuning techniques provide outstanding low-speed smoothness. The P7000 senses the motor's characteristics and automatically fine tunes itself to meet your high-performance needs. This reduces installation and set-up time.

### Mid-Band Anti-Resonance Control

Reduces negative effects of mechanical resonance, allowing you to get more out of a smaller motor and virtually eliminating nuisance stalls and machine downtime.

### Idle Current Reduction

If you do not require the motor's full torque to hold a load at rest, you can select the right amount of current (torque) to reduce motor heating and power consumption. This increases the life of the system.

### Dynamic Smoothing

Quasi-S-curve algorithm reduces jerk, especially upon acceleration. Increases mechanical life of the machine and reduces energy consumption.

### Intelligent Indexing Option (-PN)

Wizard-like P7000 helps you to develop and link motion tasks such as homing and conditional and unconditional indexing. You can be up-and-running quickly.

### Modbus RTU Compatible

The Intelligent Indexing option (-PN) supports Modbus RTU to control motion with an external interface device. External interfaces make controlling motion simple for machine operators.

### P7000 Tools

The position node option allows you to configure up to 63 absolute or relative moves. You can specify the moves' distance, acceleration, velocity, and deceleration rates, or simply specify the distance and total time for the move – P7000 will perform the calculations automatically.

Specifications	Units	P70530	P70360
Input Voltage Range	Volts	20 - 75 Vdc	120 or 240 Vac
Continuous Current	Amps rms	5	2.5
Microstep Peak Current	Amps peak	7.1	3.5

Note: For complete P7000 Series model nomenclature, refer to page 72.



# Hybrid Step Motors

Kollmorgen step motors have higher performance and support larger shaft loads than any other step motors. Custom motors are available to meet specific application needs including: modified shafts, connectors, lead-screws, and shaft-mounted components.

## CT Series

CT Series motors include the most popular sizes, options and value suitable for most commercial and industrial applications. Enhanced motors provide the maximum performance available. This patented technology boosts torque an additional 25% to 40% across the entire speed range, and allows machines to be designed that are smaller and move faster.

### CT Series Benefits

- Smaller drives result in a lower system cost
- More torque allows for smaller, faster machines
- Higher efficiency enables lower operating costs

Size 17 CT Series		2 Phase, 1.8° step motors. Frame size: 1.7 inch, 43 mm (CTP High Torque Performance Series)					
Series	Construction		Holding Torque (Motor Mounted)		Length		<ul style="list-style-type: none"> <li>• Inch or metric mounting</li> <li>• Rear shaft option</li> </ul>
	Style	Stacks	Bipolar		in	mm	
			oz-in	Nm			
CTP10	Un-Enhanced	Short	43	0.30	1.37	34.7	
CTP11		1	62	0.44	1.61	40.9	
CTP12		2	80	0.56	1.92	48.8	



Size 23 CT Series		2 Phase, 1.8° step motors. Frame size: 2.2 inch, 57 mm (CTM Enhanced-Max Torque and Efficiency, CTP High Torque Performance Series)					
Series	Construction		Holding Torque (Motor Mounted)		Length		<ul style="list-style-type: none"> <li>• Captured heavy duty bearings</li> <li>• High voltage insulation system</li> <li>• Rear shaft option</li> </ul>
	Style	Stacks	Bipolar		in	mm	
			oz-in	Nm			
CTM21	Enhanced	1	260	1.84	2.13	54.1	
CTM22		2	470	3.32	3.32	84.3	
CTP20	Un-Enhanced	Short	100	0.71	1.62	41.2	
CTP21		1	200	1.41	2.13	54.1	
CTP22		2	360	2.54	3.32	84.3	



Size 34 CT Series		2 Phase, 1.8° step motors. Frame size: 3.4 inch, 87 mm (CTM Enhanced-Max Torque & Efficiency, CTP High Torque Performance Series)					
Series	Construction		Holding Torque (Motor Mounted)		Length		<ul style="list-style-type: none"> <li>• Captured heavy duty bearings</li> <li>• High voltage insulation system</li> <li>• Standard keyway front shaft</li> <li>• Rear shaft option</li> </ul>
	Style	Stacks	Bipolar		in	mm	
			oz-in	Nm			
CTM31	Enhanced	1	690	4.9	2.54	64.5	
CTM32		2	1350	9.5	3.80	96.5	
CTM33		3	1930	13.6	5.06	129	
CTP31	Un-Enhanced	1	565	4.0	2.54	64.5	
CTP32		2	1100	7.8	3.80	96.5	
CTP33		3	1580	11.2	5.06	129	



Note: For complete CT Series model nomenclature, refer to page 73.







### N/K Series

The N/K Series are larger step motors with the power, rugged construction, and options that make these motors ideal for heavy industrial applications. Options include: IP56, terminal boxes and MS connectors. Enhanced versions provide the maximum performance torque available. This patented technology boosts torque an additional 25% to 40%. Custom motors are available to meet specific application needs including: modified shafts, connectors, lead-screws, and components mounted to the shaft.

#### N/K Series Benefits

- More torque to drive heavy loads
- Smaller drives result in a lower system cost
- Higher efficiency enables lower operating costs

Size 34 N/K		2 Phase, 1.8° step motors. Frame size: 3.4 inch, 87 mm						
	Series	Construction		Holding Torque (Motor Mounted)		Length		<ul style="list-style-type: none"> <li>• Captured heavy duty bearings</li> <li>• High voltage insulation system</li> <li>• Options: Terminal Box MS Connectors Rear Shaft Encoder Front Shaft Seal</li> </ul>
		Style	Stacks	Bipolar		in	mm	
				oz-in	Nm			
K31	Enhanced	1	830	5.9	3.7	94		
K32		2	1530	10.8	5.22	133		
K33		3	2200	15.6	6.74	171		
K34		4	2770	19.6	8.25	210		
N31	Un-Enhanced	1	650	4.6	3.7	94		
N32		2	1220	8.6	5.22	133		
N33		3	1760	12.4	6.74	171		
N34		4	2170	15.3	8.25	210		

Size 42 N/K		2 Phase, 1.8° step motors. Frame size: 3.4 inch, 87 mm						
	Series	Construction		Holding Torque (Motor Mounted)		Length		<ul style="list-style-type: none"> <li>• Captured heavy duty bearings</li> <li>• High voltage insulation system</li> <li>• Options: Terminal Box MS Connectors Rear Shaft Encoder Front Shaft Seal</li> </ul>
		Style	Stacks	Bipolar		in	mm	
				oz-in	Nm			
K41	Enhanced	1	2090	14.8	3.89	99		
K42		2	4000	28.2	5.91	150		
K43		3	5650	39.9	7.92	201		
N41	Un-Enhanced	1	1630	11.5	3.89	99		
N42		2	3140	22.2	5.91	150		
N43		3	4340	30.6	7.92	201		

Note: For complete Size 34 and 42 N/K model nomenclature, refer to pages 74 and 75 respectively.



# Optimized Solutions

**With Kollmorgen, there's always a way.** Because we have decades of experience in developing optimized solutions for motion applications, you can be confident that we can provide the answer to your motion challenges. We have a huge breadth of standard products that can be modified in varying degrees, or we can develop custom motor and electronic products for true optimization.

Working with our proven portfolio of products, we can deliver solutions quickly, often with recognized cost efficiencies and reduced lead times. That means rapid prototyping, a shorter design cycle and getting to market faster. We do it all, because motion matters.

## Optimized Solutions

---

Whether it's modifying a product from our standard catalog or a white sheet design for a custom solution, you can rely on decades of Kollmorgen expertise to solve your motion challenges and help your machine stand out from the crowd.

---

## Modified Standard

Because our application expertise runs deep and our product portfolio is so broad, we can take any standard product and modify it a lot or a little to suit many needs—in a very rapid time frame. This approach ensures quality, performance and reliability by leveraging our proven track record.

Kollmorgen application engineers have a great deal of experience helping OEM engineers achieve their objectives. Typical modifications include shaft alterations, feedback type, mounting dimensions, connectors, and making components more rugged, vacuum-rated, radiation- and explosion-proof.

---

## Custom Products

With motion as our core capability, we bring a significant history of innovation to today's engineering challenges. We leverage our design and engineering excellence and technical knowledge to deliver creative new solutions for virtually any need. Our vast experience also helps us deliver a custom product in a surprisingly short time. If you can conceive it, we can make it happen.

# Structured Development Process

Working from our broad standard product portfolio, we create fully optimized solutions through the combination of off-the-shelf products, modified standard products and completely custom components. Our proven components and technology are the foundation for all of our solutions, expediting the design cycle and ensuring optimum performance for any application.

We follow a strict and efficient development process from initial concept to volume production. This ensures that products we develop meet customer needs, are cost effective to manufacture and move quickly from prototype to production. Customer involvement is key to our process, with ongoing collaboration throughout the initiative and multiple approval points to ensure a smooth, successful design cycle from beginning to end.

## Why You Should Partner with Kollmorgen

- Experienced Application Engineers help define a customer's needs and identify the optimal Kollmorgen products and technologies
- Products optimized or developed by cross-functional teams to meet customer needs
- Rapid prototyping
- Smooth transition from prototype designs to sustainable and cost effective manufacturing
- Industry-proven quality, performance, and delivery
- Proven technology building blocks mitigate risks of customization

## Optimized Solutions Process

Comprehensive design, manufacture and test capabilities ensure the end product meets the customer performance specifications and quality requirements. Our skilled engineering team works directly with each customer throughout the process, quickly taking the prototype to full production.

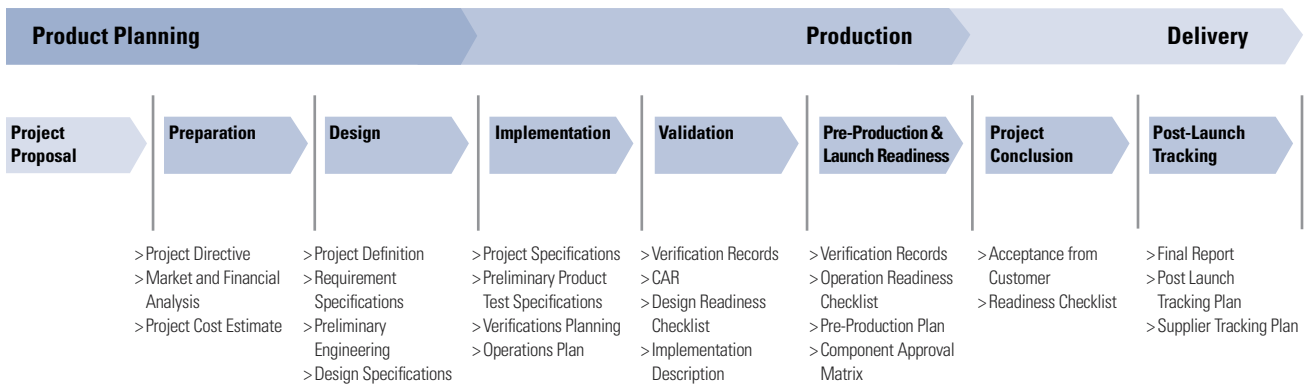

# Proven Design Capabilities

## Motor Solutions

- Brushed, brushless and stepper motor building blocks used in frameless or housed configurations
- Designed for agency compliance (UL, CE)
- Voltage ratings from 48 Vdc – 600 Vdc, with capabilities in 800 Vdc and up
- Continuous torques from 0.5 Nm – 29,000 Nm
- Proven performance and reliability in a customizable package

## Drive Solutions

- Board-level or packaged solutions supporting single to multi-axis configurations
- Brushed or Brushless Servo Drives, Stepper, AC Induction control
- Integrated Controller and Communications options
- Designed for agency approvals (UL 508C, EN 50178, EN 61000-6-6, EN 61800-3, CISPR 14-1, and others available)
- Proprietary technology and software can be embedded into the drive



Medical diagnostics drive optimized for form-factor, I/O and EMC

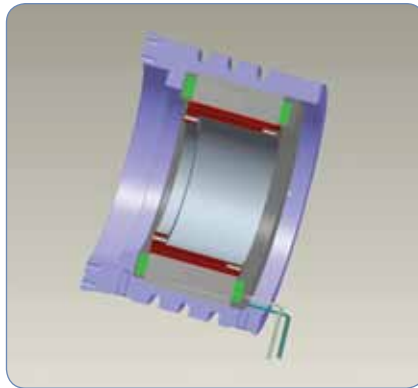

Frameless direct drive rotary motor with water cooling features

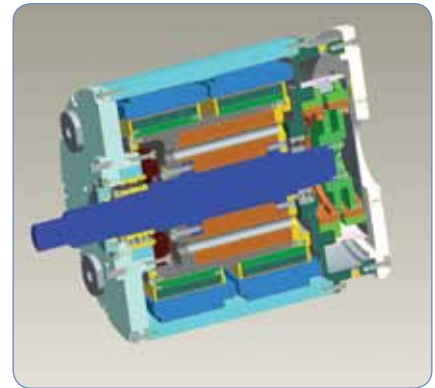

Custom submersible motor

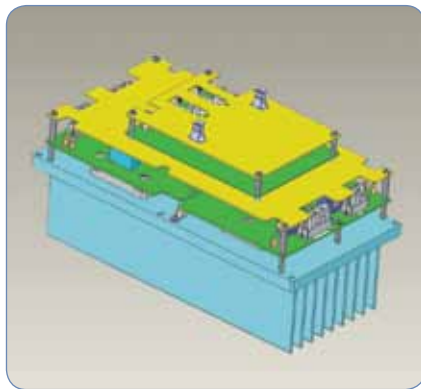

2-axis drive for high-power robotics, optimized for form-factor and communications interface



200 kW electric starter/generator

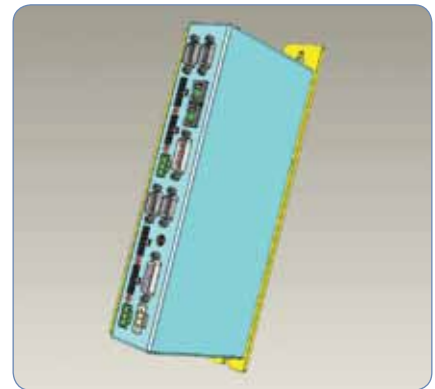

4-axis stepper drive using SynqNet

## Motors and Electronics

Optimized for	Application
Reliability	Implantable heart pumps, military, remote equipment
Precision	Pick and place, satellite tracking, film processing
Package Size	Medical imaging, ground based telescopes, aircraft instrumentation
Weight	Land vehicles, portable equipment, aircraft
Smooth Operation	Medical respirators, high precision robotics, printing and textile machines
Harsh Environments	Deep sea, outer space, high shock and vibration, extreme temperatures

# Cables by Motor Type

## Value Line Cables by Motor Type

Model	Power Cable	Power Cable with Brake Leads	SFD	EnDat2.2, 01 & BiSS
CDDR to 6 Amps	VP-507BEAN-XX	n/a	n/a	VF-SB447N-XX
CDDR to 12 Amps	VP-508CEAN-XX	n/a	n/a	VF-SB447N-XX
CDDR to 20 Amps	VP-508DEAN-XX	n/a	n/a	VF-SB447N-XX
DDR to 6 Amps	VP-507BEAN-XX	n/a	n/a	VF-SB447N-XX
DDR to 12 Amps	VP-508CEAN-XX	n/a	n/a	VF-SB447N-XX
DDR to 20 Amps	VP-508DEAN-XX	n/a	n/a	VF-SB447N-XX

XX = length in meters (1, 3, 6, 9, 12) Example: VP-507BEAN-09 (9 meter cable).  
Other feedback choices are available. Contact customer service for details.

## Flex Line Cables by Motor Type

Model	Power Cable	Power Cable with Brake Leads	SFD	EnDat2.2, 01 & BiSS
AKM to 12 Amps	CP-507CCAN-XX-X	CP-507CDAN-XX-X	CF-DA0374N-XX-X	CF-SB7374N-XX-X
AKM to 20 Amps	CP-508DCAN-XX-X	CP-508DDAN-XX-X	CF-DA0374N-XX-X	CF-SB7374N-XX-X
AKM to 24 Amps	CP-508EDBN-XX-X	CP-508EDBN-XX-X	CF-DA0374N-XX-X	CF-SB7374N-XX-X
CDDR to 12 Amps	CP-507CCAN-XX-X	n/a	n/a	CF-SB7374N-XX-X
CDDR to 20 Amps	CP-508DCAN-XX-X	n/a	n/a	CF-SB7374N-XX-X
DDR to 12 Amps	CP-507CCAN-XX-X	n/a	n/a	CF-SB7374N-XX-X
DDR to 20 Amps	CP-508DCAN-XX-X	n/a	n/a	CF-SB7374N-XX-X

Note 1: XX-X = length in half-meters up to 50 meters (1, 3, 6, 9, 12 standard) Example: CP-507CCAN-03-5 (3.5 meter cable).  
Note 2: Other feedback choices are available. Contact customer service for details.  
Note 3: Other lengths are available. Contact customer service for details.  
Note 4: Refer to page 15 for cable specifications.

## MODEL NOMENCLATURE

# AKD Servo Drive

**AKD** – **B** **003** **06** – **NA** **AN** **0000**

AKD Series

Version

**B = Base Drive**

P = Position indexer (motion tasking)

T = Structured text (basic-like)

Current Rating

003 = 3 Amp

006 = 6 Amp

012 = 12 Amp

024 = 24 Amp

Voltage

06 = 120/240 Vac 1Ø/3Ø

07 = 480 Vac 3Ø

Variants

0000 = Standard

Connectivity

**AN = Analog command**

CN = CANopen

EC = EtherCAT

Extension

**NA = Without extensions**

Note: Options shown in bold blue text are considered standard.



# AKM Brushless Servomotors

**AKM 4 2 E – E K C N C- 00**

AKM Series

Motor Frame Size

1, 2, 3, 4, 5, 6, 7

Rotor Stack Length

1, 2, 3, 4, 5

Winding Type

A, B, C, D, etc.

S = Special

Mount

**A = International standard mount**

B = NEMA mount

C = Alternative standard mount

D = Alternative standard mount

E = NEMA mount

S = Special

Shaft

C = Closed keyway

K = Open keyway

**N = Smooth shaft**

S = Special

Customization/Seal

**00 = Standard motor without shaft seal**

01 = Standard motor with shaft seal

Other numbers will be assigned for special motors.

Feedback Device

1- = 1024 PPR digital encoder with commutation

2- = 2048 PPR digital encoder with commutation

**C = Smart Feedback Device (SFD) (available across family)**

R- = Resolver

AA = BiSS single-turn absolute (AKM2-7)

AB = BiSS multi-turn absolute (AKM2-7)

DA = Single-turn absolute sine encoder (EnDat2.2, 01) (AKM2-7)

DB = Multi-turn absolute sine encoder (EnDat2.2, 01) (AKM2-7)

LB = Inductive multi-turn (AKM2-7)

Brake

2 = 24 Vdc brake (AKM2-7)

**N = No brake**

S = Special

Connectors

B = Dual motor-mounted rotatable IP65 connectors (AKM2 only)

**C = 0.5 m shielded cables with IP65 connectors (AKM1, 2), motor-mounted rotatable IP65 connectors (AKM3-7)**

G = Straight motor-mounted IP65 connectors (AKM2-7)

S = Special

Note: Options shown in bold blue text are considered standard.

# Cartridge Direct Drive Rotary (DDR) Motors

**C 09 1 A - 1 1 - 1 1 0 5 ( ) (-)**

**Cartridge DDR Series**

C = 230 Vac winding  
CH = 400/480 Vac winding

**Frame Size**

04 = 4.25" square housing  
05 = 5.43" square housing  
06 = 7.40" square housing  
09 = 9.68" square housing  
13 = 13.78" square housing

**Stack Length**

1 = Short stack  
2 = Mid stack  
3 = Long stack  
4 = Extra long stack  
(04 and 05 frame sizes only)

**Winding Type**

A, B, C, D

**Mount**

**1 = Standard flange mount**

**Connectors**

**1 = Side connector option (09 and 13 frame sizes only)**  
2 = Rear connector option (09 and 13 frame sizes only)  
**3 = 90° rotatable connectors (04, 05 and 06 frame sizes only)**

XXX

**Designated for specials. Omit for standard motor.**

**Agency Certification**

**Blank = UL/CE certification**  
S = Non-UL

**Unit Sealing**

**5 = Sealed**  
(Shaft option "1" – IP64 rating when customer seals interface side)  
(Shaft option "2" or "3" – IP65 rating when customer seals interface side)

**Bearing Option**

**0 = No bearing design (integral shipping clamp provided)**

**Feedback Device**

**1 = Sine encoder (C09 and C13)**  
**3 = Sine encoder (C04, C05 and C06)**

**Shaft**

1 = Hollow with compression coupling and key (09 and 13 frame sizes only)  
**2 = Solid with compression coupling and key (09 and 13 frame sizes only)**  
**3 = Solid with split ring coupling and no key (04, 05 and 06 frame sizes only)**

Note: Options shown in bold blue text are considered standard.

# Housed Direct Drive Motors D(H) Series

**DH 08 1 M - 1 2 - 1 3 1 0 (-)**

**Housed Direct Drive Series**

D = 115/230 Vac winding  
DH = 400/480 Vac winding

**Motor Frame Size**

06 = 6.93" O.D.  
08 = 8.60" O.D.  
10 = 11.19" O.D.  
14 = 14.25" O.D.

**Rotor Stack Length**

1 = Short stack  
2 = Mid stack  
3 = Long stack

**Winding Type**

A = Std. w/ resolver  
(all except D14x & DH14x)  
M = Std. w/ sine encoder

**Mounting Option**

1 = Face mount  
**2 = Flange mount**

XXX

**Designated for specials.  
Omit for standard motor.**

**Unit Seal**

**0 = Non-sealed unit**  
5 = IP65 (resolver models only)  
7 = IP67 (resolver models only)

**Bearing Option**

**1 = Single bearing design**  
2 = Dual bearing design (standard on D143 and DH143 models)

**Feedback Device**

2 = Resolver ("A" winding type)  
3 = Sine encoder ("M" winding type)

**Shaft Option**

**1 = Straight thru bore w/ facing coupling**

**Connector Type**

**2 = Straight**  
3 = 90°, rotatable

Note: Options shown in bold blue text are considered standard.

# DS Series Precision Tables

## DS4 – 250 – C – 5G – AKM23D – BNC ( - ) – OE6 – PR6E – LN1 – H0 ( - ) – E0 – CLN

### DS Series

DS4  
DS6

### Stroke Length

50 = 50 mm total stroke	DS4 only
100 = 100 mm total stroke	DS4 only
150 = 150 mm total stroke	DS4 only
200 = 200 mm total stroke	DS4 only
250 = 250 mm total stroke	DS4 only
300 = 300 mm total stroke	DS4 only
350 = 350 mm total stroke	DS4 only
400 = 400 mm total stroke	DS4 only
450 = 450 mm total stroke	DS4 only
500 = 500 mm total stroke	DS4 only
550 = 550 mm total stroke	DS4 only
600 = 600 mm total stroke	DS4 only
700 = 700 mm total stroke	DS6 only
800 = 800 mm total stroke	DS6 only
900 = 900 mm total stroke	DS6 only
1000 = 1000 mm total stroke	DS6 only
1250 = 1250 mm total stroke	DS6 only
1500 = 1500 mm total stroke	DS6 only
1750 = 1750 mm total stroke	DS6 only
2000 = 2000 mm total stroke	DS6 only

### Grade

**C = Commercial grade**  
P = Precision grade

### Ballscrew Lead

5G = 5 mm/rev	
10G = 10 mm/rev	
25G = 25 mm/rev	DS6 only

### Motor

AKM23C = AKM23C-EFxxx-00 brushless servo  
AKM23D = AKM23D-EFxxx-00 brushless servo  
AKM42E = AKM42E-EKxxx-00 brushless servo  
AKM42G = AKM42G-EKxxx-00 brushless servo

### Motor Options

<b>B ■■</b> = Rotatable IP65 connectors	AKM2 only
<b>C ■■</b> = 0.5 m shielded cables w/ IP65 connectors	AKM2 only
<b>C ■■</b> = Rotatable IP65 connectors	AKM4, AKM5 only
<b>■N ■</b> = No brake	
<b>■2 ■</b> = 24 Vdc power-off holding brake	
<b>■R</b> = Resolver	
<b>■2</b> = 2048 LPR incremental comm. encoder	
<b>■C</b> = Smart Feedback Device (SFD)	
<b>■DA</b> = Single-turn absolute sine encoder, EnDat2.2, 01	
<b>■DB</b> = Multi-turn absolute sine encoder, EnDat2.2, 01	
Omit if motor mount is used	

### Additional Options

P1 = Standard pinning of x-axis carriage  
CLN = Cleanroom prep – class 100  
Omit for no additional options

### Linear Decoder

**E0 = No linear encoder**  
E1 = 1 micron resolution linear encoder  
E2 = 0.5 micron resolution linear encoder  
E3 = 0.1 micron resolution linear encoder

### Shaft End Options

BS = Brake on ballscrew,  
24 Vdc power-off  
ES = Rotary encoder on ballscrew,  
1250 line  
Omit for no option

### Home Switch

**H0 = No home sensor**  
HN1 = Home, NPN type normal open  
HN2 = Home, NPN type normal closed  
HP1 = Home, PNP type normal open  
HP2 = Home, PNP type normal closed

### Limit Sensors

**L0 = No end-of-travel limits**  
LN1 = Limits, NPN type normal open  
LN2 = Limits, NPN type normal closed  
LP1 = Limits, PNP type normal open  
LP2 = Limits, PNP type normal closed

### Motor Orientation & Pulley Bore (Parallel Models)

PR6E = Parallel right  
PL6E = Parallel left  
PU6E = Parallel under  
Omit for inline models

### Couplings (Inline Models)

OE6 = Oldham style, 3/8" bore (AKM2X) DS6 only  
OE8 = Oldham style, 1/2" bore (AKM4X)  
BE6 = Bellows style, 3/8" bore (AKM2X)  
BE8 = Bellows style, 1/2" bore (AKM4X) DS6 only  
Omit for parallel models

### Motor Mounts

X23 = NEMA 23 mount  
X34 = NEMA 34 mount DS6 only  
Omit if motor option is used

Note: Options shown in bold blue text are considered standard.

# Electric Cylinders EC Series

**EC Series**    **Motor Type**    **Motor Options**    **Drive Ratio**    **Screw Lead**    **Stroke Length**    **Cylinder Mounting**    **Rod Ends**    **Options**    **Cable Option**  
**EC2** – **AKM23D** – **BNR** – **10** – **05B** – **300** – **MP2** – **FT1M** (–) – **CO**

MODEL NOMENCLATURE

## EC Series

EC1  
EC2  
EC3  
EC4  
EC5

## Motor Type

CTP12 = CTP12xLF10MMA00 stepper motor  
 AKM11B = AKM11B-ANCxx-00 brushless servo  
 AKM13C = AKM13C-ANCxx-00 brushless servo  
 AKM23D = AKM23D-EFxxx-00 brushless servo  
 AKM23C = AKM23C-EFxxx-00 brushless servo  
 AKM42G = AKM42G-EKxxx-00 brushless servo  
 AKM42E = AKM42E-EKxxx-00 brushless servo  
 AKM52G = AKM52G-EKxxx-00 brushless servo  
 AKM52L = AKM52L-EKxxx-00 brushless servo  
 X = Customer-supplied motor  
 (motor described in Options element of part number)

## Motor Options

**B ■ ■** = Rotatable IP65 connectors  
**C ■ ■** = 0.5 m shielded cables w/ IP65 connectors  
**C ■ ■** = Rotatable IP65 connectors  
**■ N ■** = No brake  
**■ 2 ■** = 24 Vdc power-off holding brake  
**■ ■ R** = Resolver  
**■ ■ 2** = 2048 LPR incremental comm. encoder  
**■ ■ C** = Smart Feedback Device (SFD)  
**■ ■ ■** = Omit field for CTP12

## Drive Ratio

10 = 1.0:1 drive belt/pulley (EC1 – helical)  
 15 = 1.5:1 drive belt/pulley  
 20 = 2.0:1 drive belt/pulley (EC1 – helical)  
 40 = 4.0:1 helical gears  
 50 = 5.0:1 helical gears  
 70 = 7.1:1 helical gears  
 100 = 10.0:1 helical gears  
 10L = 1.0:1 inline coupling (direct 1:1 coupling is the only ratio available for inline models)

## Screw Lead

03B = 0.125 in/rev ballscrew  
 05B = 5 mm/rev ballscrew  
 10B = 10 mm/rev ballscrew  
 16B = 16 mm/rev ballscrew  
 25B = 25 mm/rev ballscrew  
 32B = 32 mm/rev ballscrew  
 04A = 4 mm/rev lead screw

## Available

EC1  
EC1  
EC1  
EC2, EC3  
EC2, EC3  
EC3, EC4, EC5  
EC3, EC4, EC5  
EC4, EC5  
EC4, EC5  
All

## Available

AKM2  
AKM1, AKM2  
AKM4, AKM5  
AKM1, AKM2, AKM4, AKM5  
AKM2, AKM4, AKM5  
AKM1, AKM2, AKM4, AKM5  
AKM1, AKM2, AKM4, AKM5  
AKM1, AKM2, AKM4, AKM5  
CTP12

## Available

All  
EC2, EC3, EC4, EC5  
Not valid for EC3-AKM42  
EC1 only  
EC2, EC3, EC4, EC5  
EC3 only  
EC2, EC4, EC5  
All

## Available

EC1  
EC2, EC3  
EC3, EC4, EC5  
EC2, EC3  
EC4  
EC5  
EC2, EC3

## Stroke Length

50 = 50 mm total stroke  
 100 = 100 mm total stroke  
 150 = 150 mm total stroke  
 200 = 200 mm total stroke  
 250 = 250 mm total stroke  
 300 = 300 mm total stroke  
 450 = 450 mm total stroke  
 600 = 600 mm total stroke  
 750 = 700 mm total stroke  
 1000 = 1,000 mm total stroke  
 1250 = 1,250 mm total stroke  
 1500 = 1,500 mm total stroke  
 nnn = Custom stroke lengths available in 10 mm increments

## Cylinder Mounting

MF1 = Front rectangular flange  
 MF1E = Front rectangular flange (English)  
 MF1M = Front rectangular flange (metric)  
 MF2 = Rear rectangular flange  
 MF2E = Rear rectangular flange (English)  
 MF2M = Rear rectangular flange (metric)  
 MF3 = Front & rear rectangular flange  
 MF3E = Front & rear rectangular flange  
 MF3M = Front & rear rectangular flange  
 MP2 = Rear double clevis without pivot base  
 MP3 = Rear double clevis with pivot base  
 MS1 = Side end angle  
 MS2 = Side lugs  
**MS6M = Side tapped holes (metric)**  
 MS6E = Side tapped holes (English)  
 MT4 = Trunnion

## Rod Ends

FC2 = Clevis (includes MT1M)  
 FS2 = Spherical joint (includes FT1M)  
 FT1M = Female thread (metric)  
 FT1E = Female thread (English)  
**MT1M = Male thread (metric)**  
 MT1E = Male thread (English)  
 LR = Linear rod bearing

## Options

(add multiple in the following sequence, omit if no options)  
 BA24 = 24 Vdc brake on actuator (EC1 only, not available with 10L ratio or MS1 mounting options)  
 BS24 = 24 Vdc brake on ballscrew (not available with EC1 or 10L ratio, or with MF2(x), MF3(x), MS1, MP2(x), MP3(x) mounting options)  
 BS115 = 115 Vac brake on ballscrew (not available with EC1 or 10L ratio, or with MF2(x), MF3(x), MS1, MP2(x), MP3(x) mounting options)  
 PB = Protective boot\*  
 L = Linear potentiometer (only valid through 600 mm stroke, standard lengths)\*  
 17X = NEMA 17 mountless motor (EC1 only)

## Cable

**CO = No cable supplies, motor includes connectors.**  
**Default for all AKM Servomotors; select cable as an accessory.**

\*Contact customer service for EC1  
 Motor Mod codes for X (customer-supplied) motors also found in "Option" portion of part number. Contact customer service.  
 Motor Mod codes (customer-supplied and customer-installed)  
 IDR67X EC1 for AKM1XX-ANXXX  
 IDR60X EC2, EC3 for AKM23X-EFXXX  
 IDR61X EC3, EC4, EC5 for AKM42X-EKXXX  
 IDR62X EC4, EC5 for AKM51X-EKXXX or AKM52X-EKXXX

## Available

All  
All  
All  
All  
EC2, EC3, EC4, EC5  
EC2, EC3, EC4, EC5  
EC2, EC3, EC4, EC5  
EC2, EC3, EC4, EC5  
EC2, EC3, EC4, EC5  
EC3, EC4, EC5  
EC4, EC5  
EC4, EC5

## Available

EC1, EC2, EC3, EC5  
EC4 only  
EC4 only  
EC2, EC3, EC5  
EC4 only  
EC4 only  
EC2, EC3, EC5  
EC4 only  
EC4 only  
All  
All  
All  
All  
**All**  
EC2, EC3, EC4, EC5  
EC2, EC3, EC4, EC5

## Available

All  
All  
All  
EC2, EC3, EC4, EC5  
**All**  
EC2, EC3, EC4, EC5  
EC2 only

Note: Options shown in bold blue text are considered standard.

# Electric Cylinders N2 Series

## **N2 – AKM23D – BNR – 15 – 5B – 8 – MP2 – FT1M ( - ) – CO**

N2 Series

### Motor Type

AKM23D = AKM23D-EFxxx-00 brushless servo  
 AKM23C = AKM23C-EFxxx-00 brushless servo  
 X = Customer-supplied motor (motor described in 'Options' element of part number)

### Stack Length

**B ■ ■** = Rotatable IP65 connectors  
**C ■ ■** = 0.5 m shielded cables w/ IP65 connectors  
**■ N ■** = No brake  
**■ 2 ■** = 24 Vdc power-off holding brake  
**■ ■ R** = Resolver  
**■ ■ 2** = 2048 LPR incremental comm. encoder  
**■ ■ C** = Smart Feedback Device (SFD)

### Drive Ratio

10 = 1.0:1 drive belt/pulley  
 15 = 1.5:1 drive belt/pulley  
 20 = 2.0:1 drive belt/pulley  
 25 = 2.5:1 helical gears  
 35 = 3.5:1 helical gears  
 120 = 12.0:1 helical gears  
 10L = 1.0:1 inline coupling (direct 1:1 coupling is the only ratio available for inline models)

### Screw Pitch, Type

2B = 2 rev/inch ballscrew  
 5B = 5 rev/inch ballscrew  
 5A = 5 rev/inch lead screw  
 8A = 8 rev/inch lead screw

### Stroke Length

2 = 2 inch total stroke  
 4 = 4 inch total stroke  
 6 = 6 inch total stroke  
 8 = 8 inch total stroke  
 12 = 12 inch total stroke  
 18 = 18 inch total stroke (requires -DB option, effective stroke is 16.5")  
 24 = 24 inch total stroke (requires -DB option, effective stroke is 22.5")  
 nn.n = Custom stroke lengths available in 0.1 inch increments

### Cable

**CO = No cable supplied, motor includes connectors. Default for all AKM Servo-motors; select cable as an accessory.**

### Options

(add multiple in the following sequence, omit if no options)

**DB** = Dual front braking  
**BS24** = 24 Vdc brake on lead screw (not available with 10L ratio, or with MF2, MF3, MS2, MP2, MP3 mounting options)  
**PB** = Protective boot  
**W** = Water resistant  
**F** = Sub-freezing temperature  
**H** = High temperature prep  
**L** = Linear potentiometer (only for valid std. lengths)  
 Motor Mod codes for X (customer-supplied) motors also found in "Option" portion of part number. Contact customer service.  
 Motor Mod codes (customer-supplied and customer-installed)  
 IDR60X N2 for AKM23X-EFXXX

### Rod Ends

**FC2 = Clevis (includes MT1M)**  
**FS2** = Spherical joint (includes FT1M)  
**FT1M** = Female thread (metric)  
**FT1E** = Female thread (English)  
**MT1M** = Male thread (metric)  
**MT1E** = Male thread (English)

### Cylinder Mounting

**MF1 = Front rectangular flange**  
**MF2** = Rear rectangular flange  
**MF3** = Front & rear rectangular flange  
**MP2** = Rear double clevis without pivot base  
**MP3** = Rear double clevis with pivot base  
**MS1** = Side end angle  
**MS2** = Side lugs  
**MS6M** = Side tapped holes (metric)  
**MS6E** = Side tapped holes (English)  
**MT4** = Trunion

Note: Options shown in bold blue text are considered standard.

# Rodless Actuators R-Series

## R3 – AKM42G CNC – 10 5B – 12 – P – A S E – CO

### R Series

R2A  
R3  
R4

### Motor Type

AKM23C = AKM23C-EFxxx-00 brushless servo  
AKM23D = AKM23D-EFxxx-00 brushless servo  
AKM42E = AKM42E-EKxxx-00 brushless servo  
AKM42G = AKM42G-EKxxx-00 brushless servo  
AKM52G = AKM52G-EKxxx-00 brushless servo  
AKM52H = AKM52H-EKxxx-00 brushless servo  
X = Customer-supplied motor

### Available

R2A, R3  
R2A, R3  
R3, R4  
R3, R4  
R4  
R4

### Motor Options

**B** = Rotatable IP65 connectors  
**C** = 0.5 m shielded cables w/ IP65 connectors  
**C** = Rotatable IP65 connectors  
**N** = No brake  
**2** = 24 Vdc power-off holding brake  
**R** = Resolver  
**2** = 2048 LPR incremental comm. encoder  
**C** = Smart Feedback Device (SFD)

### Available

AKM2  
AKM2  
AKM4, AKM5  
AKM2, AKM4, AKM5  
AKM2, AKM4, AKM5  
AKM2, AKM4, AKM5  
AKM2, AKM4, AKM5  
AKM2, AKM4, AKM5

### Drive Ratio

10 = 1.0:1 drive belt/pulley  
15 = 1.5:1 drive belt/pulley  
20 = 2.0:1 drive belt/pulley  
30 = 3.0:1 drive belt/pulley  
50 = 5:1 helical gear  
70 = 7:1 helical gear  
100 = 10:1 helical gear

### Available

R2A, R3, R4  
R2A, R3, R4  
R2A, R3, R4  
R4  
R3, R4  
R3  
R3

### Linear Drive Type

5A = 5 pitch (0.2" lead) lead screw  
8A = 8 pitch (0.125" lead) lead screw  
1B = 1 pitch (1" lead) ballscrew  
2B = 2 pitch (0.5" lead) ballscrew  
4B = 4 pitch (0.25" lead) ballscrew  
5B = 5 pitch (0.2" lead) ballscrew  
T = Tangential drive belt

### Available

R2A, R3  
R2A, R3  
R4  
R2A, R3  
R4  
R2A, R3  
R2A, R3, R4

### Stroke Length

6 = 6" of total stroke  
12 = 12" of total stroke  
18 = 18" of total stroke  
24 = 24" of total stroke  
30 = 30" of total stroke  
36 = 36" of total stroke  
42 = 42" of total stroke  
48 = 48" of total stroke  
54 = 54" of total stroke  
60 = 60" of total stroke  
66 = 66" of total stroke  
72 = 72" of total stroke  
84 = 84" of total stroke  
96 = 96" of total stroke  
108 = 108" of total stroke  
Custom lengths available in the increment of 1"

### Available

R2A, R3, R4  
R2A, R3, R4  
R2A, R3, R4  
R2A, R3, R4  
R2A, R3, R4  
R2A, R3, R4  
R2A, R3, R4  
R2A, R3, R4  
R2A, R3, R4  
R2A, R3, R4  
R2A, R3, R4  
R2A, R3, R4  
R3, R4  
R3, R4  
R3, R4

### Options

BS24 = 24 Vdc brake on lead screw  
(Screw option only, n/a with inline models, MF3 or "C" options) R2A, R3, R4  
BS115 = 115 Vdc brake on lead screw  
(Screw option only, n/a with inline models, MF3 or "C" options) R2A, R3, R4  
BS230 = 230 Vdc brake on lead screw  
(Screw option only, n/a with inline models, MF3 or "C" options) R2A, R3, R4  
WR = Water resistant seal option right R2A  
WL = Water resistant seal option left R2A  
GR = Lube port, right side R3, R4  
GL = Lube port, left side R3, R4  
DC1 = Idler carriage between driven carriage and non-motor end R2A  
DC2 = Idler carriage between driven carriage and motor end R2A  
VR = Breather vent, fitting, tubing, right side R4  
VL = Breather vent, fitting, tubing, left side R4  
**CO = No motor cable** **R2A, R3, R4**  
S = Stub shaft R2A

### Available

### English/Metric

(carriage/mounting) Available  
E = English carriage & mounting dimensions R2A, R3, R4  
M = Metric carriage & mounting dimensions R2A, R3, R4

### Carriage

(omit this field for R2A models) Available  
**S = Single carriage** **R3, R4**  
Dxx = Dual carriage (screw-drive only) R3, R4  
(xx = center distance between dual carriages in inches – contact customer service for lengths)

### Mounting Style

Available  
MF3 = Front & rear rectangular flanges R2A  
MS1 = Side end angles R2A  
MS5 = Adjustable feet R2A  
MS6 = Side tapped mounting holes R2A  
A = Side angle brackets R3, R4  
B = Adjustable T-nuts R3, R4  
C = Front & rear rectangular flanges R3, R4

### Motor Orientation

Available  
*Belt options*  
AR = Motor housing rotated above/right R2A, R3, R4  
BR = Motor housing rotated behind/right R2A, R3, R4  
CR = Motor housing rotated under/right R2A, R3, R4  
AL = Motor housing rotated above/left R2A, R3, R4  
BL = Motor housing rotated behind/left R2A, R3, R4  
CL = Motor housing rotated under/left R2A, R3, R4  
*Screw options*  
I = Motor mounted inline R2A, R3, R4  
P = Motor mounted parallel R2A, R3, R4  
PR = Motor mounted parallel/right R2A, R3, R4  
PL = Motor mounted parallel/left R2A, R3, R4

Note: Options shown in bold blue text are considered standard.



# Micron™ TRUE Planetary™ Gearheads

**DTR 115 – 005 – 0 – ( )**

**Gearhead Series**

- NT = NemaTRUE™
- NTP = NemaTRUE PLUS™
- NTR = NemaTRUE 90™
- XT = XTRUE™
- ET = EverTRUE™
- DT = DuraTRUE™
- DTR = DuraTRUE 90™
- DTRS = DuraTRUE™ Slimline
- DTRH = DuraTRUE™ Hollow Shaft
- DTRD = DuraTRUE™ Dual Shaft
- VT = ValueTRUE™
- VTR = ValueTRUE 90™
- UT = UltraTRUE™
- UTR = UltraTRUE 90™

**Motor Model Number**

RediMount number (if available)  
or motor manufacturer and model number

**Customer Options**

- 0 = None
- S = Special
- H = High precision  
(for NemaTRUE™ product line only)

**Gearhead Ratio**

See ratio availability in corresponding gearhead section (pp 51-53)

**Gearhead Size**

- NemaTRUE™**  
**NemaTRUE PLUS™**  
**NemaTRUE 90™**
- 17 = Size 17
  - 23 = Size 23
  - 34 = Size 34
  - 42 = Size 42
  - 60 = Size 60
  - 90 = Size 90
  - 115 = Size 115

- XTRUE™**
- 040 = Size 40
  - 060 = Size 60
  - 080 = Size 80
  - 120 = Size 120
  - 160 = Size 160

- EverTRUE™**
- 10 = Size 10
  - 14 = Size 14
  - 18 = Size 18

- DuraTRUE™**  
**DuraTRUE 90™**  
**DuraTRUE™ Slimline**  
**DuraTRUE™ Hollow Shaft**  
**DuraTRUE™ Dual Shaft**
- 60 = Size 60
  - 90 = Size 90
  - 115 = Size 115
  - 142 = Size 142

- ValueTRUE™**  
**ValueTRUE 90™**
- 006 = Size 60
  - 075 = Size 75
  - 090 = Size 90
  - 010 = Size 10
  - 115 = Size 115
  - 014 = Size 14
  - 018 = Size 18
  - 022 = Size 22

- UltraTRUE™**  
**UltraTRUE 90™**
- 006 = Size 60
  - 075 = Size 75
  - 090 = Size 90
  - 010 = Size 10
  - 115 = Size 115
  - 014 = Size 14
  - 018 = Size 18
  - 022 = Size 22 (UltraTRUE™ only)

Note: Options shown in bold blue text are considered standard.

# P7000 Stepper Drive

**P7 03 6 0 - SD N (-)**

P7000 Series

Current Rating

03 = 2.5 Arms continuous, 3.5 Arms peak  
(AC models only)

05 = 5 Arms continuous, 7.1 Arms peak  
(DC models only)

Voltage Range

3 = 20 – 75 Vdc

6 = 120/240 Vac

Electrical Options

**0 = None**

Customization

Omit field for standard configurations

Feedback Device Support

**N = None**

Functionality

PN = Motion node indexing

**SD = Step/direction base drive**

R4 = RS485 (P70360 only)

Note: Options shown in bold blue text are considered standard.

# CT Series Step Motors

**CTM 2 1 N L F 10 N AA 00**

**CT Series**

CTM = Cool Torque Maximum series  
CTP = Cool Torque Performance series

**Frame Size**

1 = Size 17 / 4.2 cm (CTP only)  
2 = Size 23 / 5.7 cm  
3 = Size 34 / 8.5 cm

**Length**

0 = Short stack (CTP only)  
1 = 1 stack  
2 = 2 stacks  
3 = 3 stacks

**Mounting**

N = NEMA through holes (size 23 & 34 only)  
E = English tapped holes (size 17 only)  
M = Metric tapped holes (size 17 only)

**Construction/Connection Style**

**L = Leads**  
S = Special

**Number of Connections**

**F = Four**  
S = Six

**Customization**

**00 = Standard motor**  
Other numbers serially assigned for special motors

**Rear Options**

**AA = None**  
EE = English rear shaft & encoder mounting holes (size 23 & 34 only)  
MA = Metric rear shaft (size 17 only)  
SS = Special

**Front Shaft Options**

N = Round smooth shaft (size 23 only)  
F = Flat (size 23 only)  
K = Straight keyway (size 34 only)  
M = Metric (size 17 only)  
S = Special

**Winding Current**

For 4 lead motors = bipolar current x 10  
For 6 lead motors = unipolar current x 10  
Examples:  
05 = 0.5 Amps  
10 = 1 Amp  
50 = 5 Amps  
00 = Special

Note: Options shown in bold blue text are considered standard.

# NEMA 34 K and N Series Step Motors

**N 3 3 H C H J - L E K - M2 - 01**

**K and N Series**

K = Enhanced  
N = Standard

**Size**

3 = NEMA 34 frame size;  
3.38" width/height, square frame

**Length**

1 = 1 stack  
2 = 2 stacks  
3 = 3 stacks  
4 = 4 stacks

**Mounting**

**H = Heavy duty NEMA**  
S = Special, contact customer service

**Construction/Connection Style**

**R = Regular/leadwire**  
C = System MS connector  
L = Splashproof/to terminal board via  
conduit connector: 1/2" NPSC pipe thread  
M = Splashproof/to terminal board via  
conduit connect: metric PG11 pipe thread  
S = Special, contact customer service

**Number of Connections**

**F = 8 lead (n/a C construction)**  
L = 4 lead series  
H = 4 lead parallel  
E = 6 lead (n/a C construction)

**Special Sequence**

**00 = Standard motor without shaft seal**  
01 = Standard motor with shaft seal  
Other numbers will be assigned for special motors

**Encoder Option**

**NS = No feedback**  
M2 = Encoder mounting provision  
(must use construction C or R and shaft configuration E)  
SS = Special, contact customer service

**Shaft Modifications**

**K = Straight key**  
S = Special, contact customer service

**Shaft Configuration (Diameter & Length)**

**N = Single**  
D = Double (R or C construction only)  
E = Double ended for encoder  
(R or C construction only)

**Rotor Type**

**L = Laminated**

**Winding Type**

H = Standard, 1 stack only  
J = Standard  
K = Standard  
M = Standard  
(not available on 1 stack only)  
S = Special, contact customer service

Note: Options shown in bold blue text are considered standard.

# NEMA 42 K and N Series Step Motors

**K 4 3 H C H J - L E K - M2 - 01**

**K and N Series**

K = Enhanced  
N = Standard

**Size**

4 = NEMA 42 frame size;  
4.325" width/height, square frame

**Length**

1 = 1 stack  
2 = 2 stack  
3 = 3 stack

**Mounting**

**H = Heavy duty NEMA**  
S = Special, contact customer service

**Construction/Connection Style**

**R = Regular/leadwire**  
C = System MS connector  
L = Splashproof/to terminal board via  
conduit connector: 1/2" NPSC pipe thread  
M = Splashproof/to terminal board via  
conduit connect: metric PG13.5 pipe thread  
S = Special, contact customer service

**Number of Connections**

F = 8 lead (n/a C construction)  
L = 4 lead series  
H = 4 lead parallel  
E = 6 lead (n/a C construction)

**Special Sequence**

**00 = Standard motor without shaft seal**  
01 = Standard motor with shaft seal  
Other numbers will be assigned for special motors

**Encoder Option**

**NS = No feedback**  
M2 = Encoder mounting provision  
(must use construction C or R and shaft configuration E)  
SS = Special, contact customer service

**Shaft Modifications**

**K = Straight key**  
S = Special, contact customer service

**Shaft Configuration (Diameter & Length)**

**N = Single**  
D = Double (R or C construction only)  
E = Double ended for encoder  
(R or C construction only)  
S = Special, contact customer service

**Rotor Type**

**L = Laminated**

**Winding Type**

J = Only on 1 stack  
K = N/A on 1 stack  
L = N/A on 1 stack  
N = N/A on 1 stack  
M = Standard  
S = Special, contact customer service

Note: Options shown in bold blue text are considered standard.

# NOTES:

A large rectangular area filled with a fine grid of light gray lines, intended for writing notes. The grid consists of approximately 30 columns and 40 rows of small squares.

# MOTIONEERING® Application Engine

To help select and size Kollmorgen components, this Windows®-based motor-sizing program takes a systems approach to the selection of brushless, DC servomotors, stepper motors and drives. MOTIONEERING® Application Engine uses a project concept for the collection and saving of rotary and linear multi-axis load information. This provides the user the flexibility to sum the effects of multiple axes of motion for power supply and shunt regeneration sizing.

A wide variety of linear and rotary mechanisms are provided including lead screw, rack and pinion, conveyor, nip rolls, cylinder, rotary, and direct data-entry using unique sizing algorithms and product databases criteria.

The searchable database consists of hundreds of systems on product combinations including rotary housed and frameless brushless servomotors, direct drive rotary and linear brushless servomotors, linear positioners (electric cylinders, rodless actuators, and precision tables) and stepper systems.

The Application Engine also provides versatile units-of-measure selection options for mechanism and motion profile data-entry, with the ability to convert data into other available units. Online Help explains program functions and the definition of terms and equations used in the program.

## Features

- Group multiple mechanisms within a “Project” – organize and combine data for power supply and regeneration sizing
- Types of mechanisms for analysis include lead screw, rack and pinion, conveyor, nip rolls, rotary and direct drive linear motor
- Motion profile options include simple triangle, 1/3-1/3-1/3 trapezoidal, variable traverse trapezoidal, and more
- Search results display shows color highlighted solution set of options for easy evaluation of system specifications and selection

## Supported Operating Systems

- Microsoft® Windows 2000, XP, Vista

## MOTIONEERING 6.0 includes

- Electric Cylinder sizing and selection with AKM Servomotor systems
- Rodless Actuator with AKM Servomotor systems (performance curves included)
- Precision Table with AKM Servomotor systems (performance curves included)
- PDF report functionality (includes application, drive, motor, positioner, and system specifications all in one easy-to-read report)

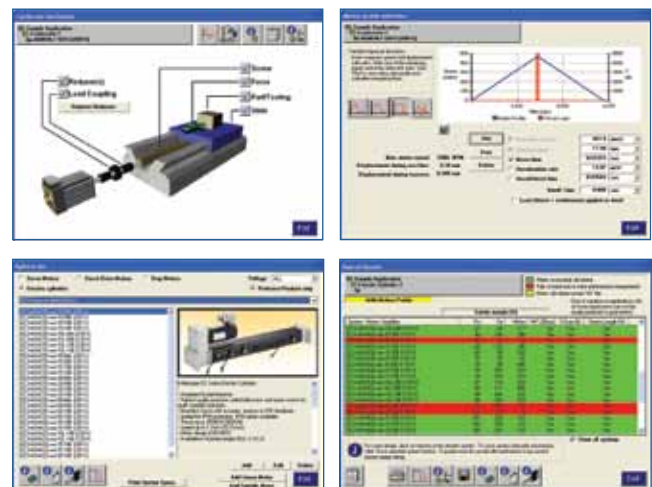



## About Kollmorgen

Kollmorgen is a leading provider of motion systems and components for machine builders. Through world-class knowledge in motion, industry-leading quality and deep expertise in linking and integrating standard and custom products, Kollmorgen delivers breakthrough solutions that are unmatched in performance, reliability and ease-of-use, giving machine builders an irrefutable marketplace advantage.

**For assistance with your application needs in North America, contact us at: 540-633-3545, [contactus@kollmorgen.com](mailto:contactus@kollmorgen.com) or visit [www.kollmorgen.com](http://www.kollmorgen.com) for a global contact list.**

- Application Centers
- Global Design & Manufacturing
- Global Manufacturing

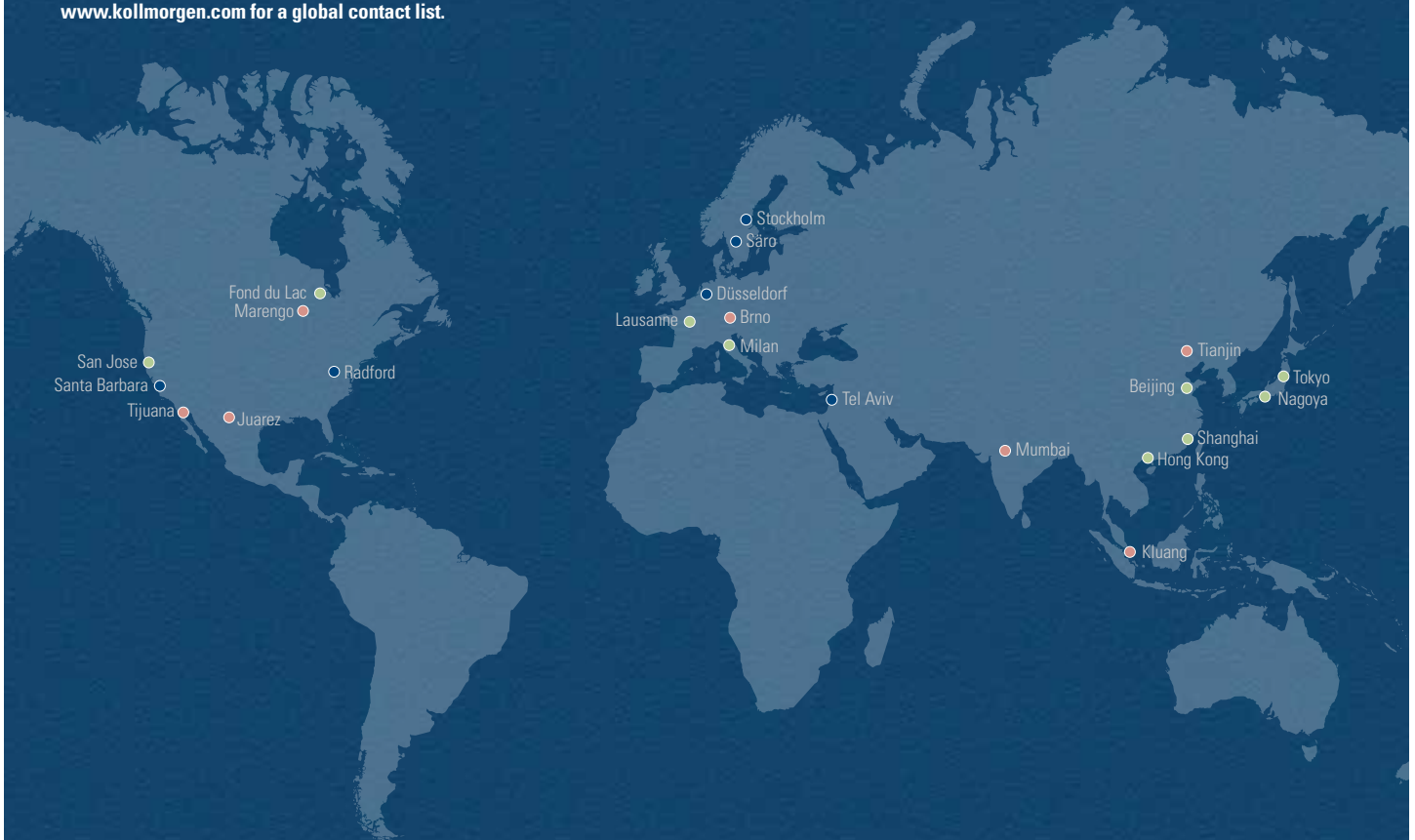

**KOLLMORGEN**®

*Because Motion Matters™*

Kollmorgen  
203A West Rock Road  
Radford, VA 24141 USA  
Phone: 1-540-633-3545  
Fax: 1-540-639-4162